



KOH-I-NOOR

25

Accessori e complementi

Accesorios de pared y complementos

Wall accessories and complements

Zubehör und einrichtungszubehör

Accessoires à percer et compléments





© 2023 KOH-I-NOOR srl

Credits:

Still life:
Studio KOH-I-NOOR
Olek Bortel Photography

Virtual set:
WOLF Visualizing Architecture
SENERIA Maciej Niezgódka

Thanks to:
Fima Carlo Frattini spa
Olympia Ceramica srl
Vismaravetro srl

Finito di stampare: Marzo 2023

INDICE

Indice // Index // Inhalt // Index

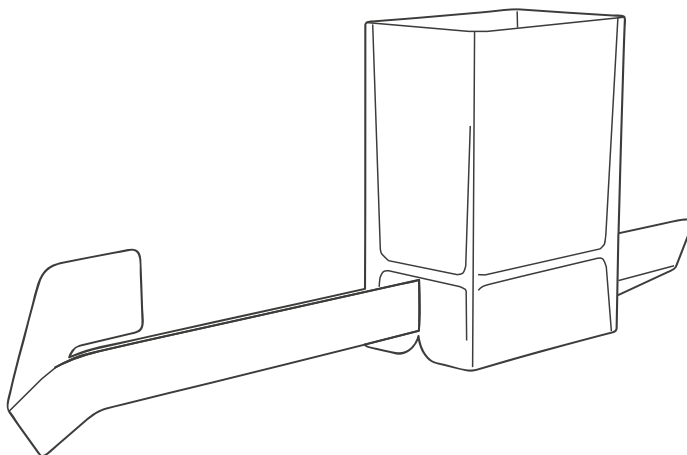

ACCESSORI	p.20
<i>Accesorios de pared</i>	
<i>Wall accessories</i>	
<i>Zubehör für Wandmontage</i>	
<i>Accessoires à fixer</i>	
IL MONDO DELLA DOCCIA	p.66
<i>El mundo de la ducha</i>	
<i>The shower's world</i>	
<i>Die Welt der Dusche</i>	
<i>Le monde de la douche</i>	
COMPLEMENTI	p.88
<i>Complementos de decoración</i>	
<i>Complements</i>	
<i>Einrichtungszubehör</i>	
<i>Compléments pour la salle de bain</i>	
HOTELLERIE	p.112
<i>Hotellerie</i>	
<i>Hotellerie</i>	
<i>Hotellerie</i>	
<i>Hotellerie</i>	
RICAMBI	p.120
<i>Piezas de recambio</i>	
<i>Spare parts</i>	
<i>Ersatzteile</i>	
<i>Pièces de rechange</i>	



KOH-I-NOOR



LA NOSTRA STORIA

Nel 1943 Carlo Scavini fonda la società Koh-I-Noor di Carlo Scavini & C. che rileva dalla Bustenfabrik di Bratislava il marchio ed il know-how.

Nel 1964 viene inaugurato lo stabilimento di Tradate (Varese), in Lombardia, dove ancora oggi ha luogo la produzione.

Negli anni, l'offerta si amplia con spazzole per capelli, pettini, pennelli da barba e specchi da trucco, diventando sempre più il riferimento negli articoli di alta gamma per la cura della persona.

Nel 1995 Koh-I-Noor inaugura la divisione dedicata alla produzione di accessori e complementi per l'arredo bagno.

Nel 2005 Koh-I-Noor apre la filiale in Spagna con sede a Barcellona. Nel 2014 Koh-I-Noor inaugura il reparto produttivo interamente dedicato alle Specchiere illuminate per l'Arredo Bagno.

Koh-I-Noor è tuttora un'azienda di famiglia gestita dai discendenti di Carlo Scavini.



KOH-I-NOOR

NUESTRA HISTORIA

En 1943 Carlo Scavini funda la empresa Koh-I-Noor di Carlo Scavini & C., que retoma de Bustenfabrik de Bratislava la marca y el saber hacer.

En 1964, la fábrica de Tradate (Varese), en Lombardía, donde se sigue produciendo hoy en día, producción sigue teniendo lugar hoy en día.

Con el paso de los años, la oferta se amplió para incluir cepillos para el pelo peines, brochas de afeitador y espejos de maquillaje, convirtiéndose cada vez más en la referencia en artículos de cuidado personal de gama alta.

En 1995 Koh-I-Noor inauguró la división dedicada a la producción de accesorios y complementos para mobiliario de baño.

En 2005 Koh-I-Noor abrió su filial en España con sede en Barcelona.

En 2014 Koh-I-Noor inaugura el departamento de producción enteramente dedicado a espejos iluminados para muebles de baño.

Koh-I-Noor sigue siendo una empresa familiar dirigida por los descendientes de Carlo Scavini.

OUR HISTORY

In 1943 Carlo Scavini founded the company Koh-I-Noor di Carlo Scavini & C., which takes over from Bustenfabrik of Bratislava the brand and the know-how.

In 1964, the factory in Tradate (Varese), in Lombardy, where production still takes place today.

Over the years, the offer expanded to include hair brushes combs, shaving brushes and make-up mirrors, increasingly becoming the reference in high-end personal care articles.

In 1995 Koh-I-Noor inaugurated the division dedicated production of accessories and complements for bathroom furnishings.

In 2005 Koh-I-Noor opened its subsidiary in Spain with headquarters in Barcelona.

In 2014 Koh-I-Noor inaugurates the production department entirely dedicated to illuminated mirrors for Bathroom Furniture.

Koh-I-Noor is still a family business run by the descendants of Carlo Scavini.

UNSERE GESCHICHTE

1943 gründete Carlo Scavini das Unternehmen Koh-I-Noor di Carlo Scavini & C., die die Marke und das Know-how von der Bustenfabrik aus Bratislava die Marke und das Know-how übernimmt.

Im Jahr 1964 wurde die Fabrik in Tradate (Varese) in der Lombardei eröffnet, wo die Produktion noch heute stattfindet.

Die Produktion findet auch heute noch statt. Im Laufe der Jahre erweiterte sich das Angebot um Haarbürsten

Kämme, Rasierpinsel und Make-up-Spiegel. Schminkspiegel, die sich immer mehr zur Referenz für für hochwertige Körperpflegeartikel.

1995 eröffnete Koh-I-Noor die Abteilung für die Produktion von Accessoires und Ergänzungen für Badezimmerinrichtungen.

Im Jahr 2005 eröffnet Koh-I-Noor seine Tochtergesellschaft in Spanien mit Sitz in Barcelona.

2014 weiht Koh-I-Noor eine Produktionsabteilung ein die sich ausschließlich mit beleuchteten Spiegeln für Badezimmermöbel.

Koh-I-Noor ist immer noch ein Familienunternehmen, das von den Nachkommen von Carlo Scavini geführt.

NOTRE HISTOIRE

En 1943, Carlo Scavini fonde la société Koh-I-Noor di Carlo Scavini & C., qui reprend la marque et le savoir-faire de Bustenfabrik de Bratislava la marque et le savoir-faire.

En 1964, l'usine de Tradate (Varese), en Lombardie, où la production se déroule encore aujourd'hui.

Au fil des ans, l'offre s'est élargie aux brosses à cheveux, aux peignes, aux blaireaux et aux brosses de rasage, peignes, les blaireaux et les miroirs de maquillage, qui deviennent de plus en plus la référence en matière d'articles de soins personnels haut de gamme.

En 1995, Koh-I-Noor a inauguré la division consacrée à la production d'accessoires et de compléments pour les produits de soins personnels à la production d'accessoires et de compléments pour les salles de bains.

En 2005, Koh-I-Noor a ouvert sa filiale en Espagne siège à Barcelone.

En 2014, Koh-I-Noor inaugure le département de production entièrement dédié aux miroirs lumineux pour meubles de salle de bains.

Koh-I-Noor est toujours une entreprise familiale dirigée par les descendants de Carlo Scavini.



KOH-I-NOOR

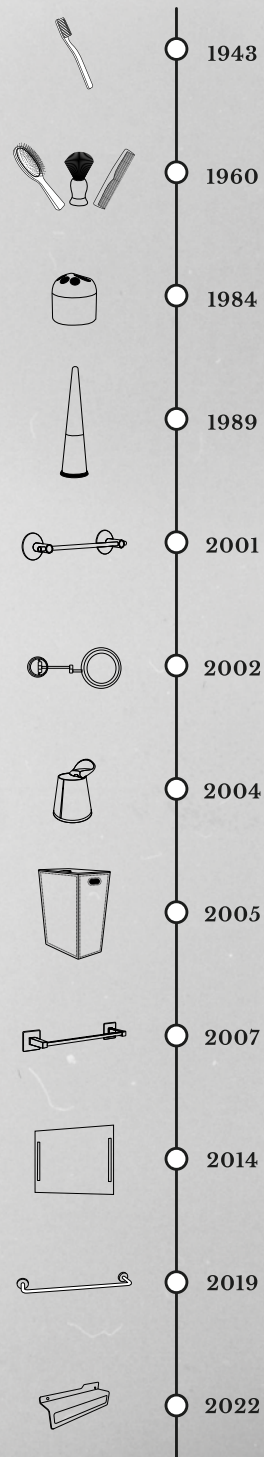

MARCHIO STORICO

Recentemente la nostra società ha ottenuto l'iscrizione all'albo dei marchi storici istituito dal Ministero delle Sviluppo Economico (MISE) che riconosce questo importante attestato alle imprese che da più di 50 anni hanno distribuito ininterrottamente il loro marchio nel mercato nazionale.

Dal 1943 operiamo con passione e professionalità connessa inscindibilmente con il made in Italy.

L'attività è iniziata con la produzione di spazzolini da denti e a seguire, attraverso la passione e la professionalità del suo fondatore Carlo Scavini e dei successori componenti della famiglia, si è via via sviluppata per offrire prodotti dedicati alla cura della persona e all'arredamento del bagno.

È un piacere oggi condividere con orgoglio questo riconoscimento con tutti coloro che in questi lunghi anni con la loro collaborazione e la loro attenzione ci hanno consentito di raggiungere questo importante risultato.



● 2022



MARCA HISTÓRICA

En 2022 nuestra sociedad ha obtenido la inscripción en el registro de marcas históricas establecidas por el Ministerio de Desarrollo Económico (MISE) que reconoce este importante certificado a las empresas que por más de 50 años han distribuido continuamente su marca en el mercado nacional. Trabajamos con pasión desde 1943 y profesionalismo conectado inseparablemente con el made in Italy. El negocio comenzó con la producción de cepillos de dientes y seguir, a través de la pasión y la profesionalidad de su fundador Carlo Scavini y sucesores familiares, se ha desarrollado para ofrecer productos dedicado al cuidado personal e al mobiliario de baño. Es un placer hoy compartir con muy orgulloso de este reconocimiento con todos aquellos en estos largos años con su colaboración y la su atención nos permitieron para lograr este importante resultado.

HISTORICAL BRAND

In 2022 our society has obtained enrollment in the register of historical brands established by the Ministry of Development Economic (MISE) which recognizes this important certificate to companies that give more than 50 years have distributed continuously their brand in the national market. We have been working with passion since 1943 and connected professionalism inseparably with the made in Italy. The business started with the production of toothbrushes and to follow, through passion and the professionalism of its founder Carlo Scavini and successors members of the family, has developed to offer products dedicated to personal care e to bathroom furnishings. It is a pleasure today to share with very proud of this recognition with all those in these long years with their collaboration and the their attention they allowed us to achieve this important result.

HISTORISCHE MARKE

Im Jahr 2022 unsere Gesellschaft die Eintragung in das Register erhalten hat historischer Marken etabliert vom Ministerium für wirtschaftliche Entwicklung (MISE), das es anerkennt dieses wichtige Zertifikat an Unternehmen, die mehr geben als 50 Jahre verteilt haben kontinuierlich ihre Marke auf dem nationalen Markt. Seit 1943 arbeiten wir mit Leidenschaft und verbundener Professionalität untrennbar mit dem made in Italien. Das Geschäft begann mit der Herstellung von Zahnbürsten und zu folgen, durch Leidenschaft und die Professionalität seines Gründers Carlo Scavini und Nachfolger Familienmitglieder, hat sich entwickelt, um Produkte anzubieten gewidmet der Körperpflege e bis hin zur Badausstattung. Es ist heute ein Vergnügen, mit ihm zu teilen sehr stolz auf diese Anerkennung mit all die in diesen langen Jahren mit ihrer Zusammenarbeit und der ihre Aufmerksamkeit, die sie uns gewährten um dies zu erreichen wichtig Ergebnis.

MARQUE HISTORIQUE

En 2022 notre entreprise a obtenu son inscription au registre de marques historiques implantées par le ministère du Développement Économique (MISE) qui reconnaît ce certificat important aux entreprises qui donnent plus de 50 ans ont distribué continuellement leur marque sur le marché national. Nous travaillons avec passion depuis 1943 et professionnalisme connecté indissociablement du made in Italy. L'entreprise a commencé avec le fabrication de brosses à dents et de suivre, par passion et le professionnalisme de son fondateur Carlo Scavini et successeurs membres de la famille, nous sommes loin façon développée pour offrir des produits dédié aux soins personnels e à l'ameublement de la salle de bain. C'est un plaisir aujourd'hui de partager avec Je suis fier de cette reconnaissance avec tous ceux dans ces longs ans avec leur collaboration et la leur attention ils nous ont permis pour réaliser cet important résultat.



KOH-I-NOOR

MARCHIO
STORICO

LA NOSTRA PRODUZIONE

Lo Studio di progettazione interno, in collaborazione con qualificati designer italiani e stranieri, crea i prodotti con un'attenzione particolare rivolta alla tecnologia, all'innovazione e al design, sempre seguendo l'impronta che ha caratterizzato la storia dell'azienda.

Ogni prodotto deve superare severi test di funzionalità e durevolezza. I processi produttivi, in gran parte manuali, consentono di sviluppare le migliori tecniche nell'ambito dell'artigianato industriale e il controllo qualità si basa su standard molto elevati. Inoltre la presenza di un Ufficio Tecnico interno di ricerca e sviluppo consente di creare prodotti su misura, personalizzati e in grado di soddisfare le molteplici esigenze della nostra clientela.



NUESTRA PRODUCTION

El estudio de diseño propio, en colaboración con cualificados diseñadores italianos y extranjeros, crea los productos con una atención particular a la tecnología, a la innovación y al diseño, siguiendo siempre la huella que ha caracterizado la historia de la empresa.

Cada producto debe pasar pruebas de funcionalidad y durabilidad estrictas. Los procesos de producción, en gran parte manuales, permiten desarrollar las mejores técnicas en el ámbito de la artesanía industrial con controles de calidad, basados en normas muy estrictas. Además, la presencia de una Oficina Técnica Interna de Investigación y Desarrollo permite crear productos a medida, personalizados y capaces de satisfacer las múltiples exigencias de nuestra clientela.

OUR PRODUCTION

The internal design studio, in collaboration with qualified Italian and foreign designers, creates products with particular attention to technology, innovation and design, always following the footprint that has characterized the company's history.

Each product has to pass strict functionality and durability tests. The production processes, mostly manual, allow for the development of the best techniques in the field of industrial craftsmanship and quality control is based on very high standards. In addition, the presence of an internal technical research and development office allows us to create tailor-made products, customized and able to satisfy the multiple needs of our customers.

NOTRE PRODUCTION

Le studio de design interne, en collaboration avec des designers italiens et étrangers qualifiés, crée des produits avec une attention particulière à la technologie, à l'innovation et au design, en suivant toujours l'empreinte qui a caractérisé l'histoire de l'entreprise.

Chaque produit doit passer des tests stricts de fonctionnalité et de durabilité. Les processus de production, pour la plupart manuels, permettent le développement des meilleures techniques dans le domaine de l'artisanat industriel et le contrôle de la qualité est basé sur des normes très élevées. De plus, la présence d'un bureau de recherche et développement technique interne nous permet de créer des produits sur mesure, personnalisés et capables de satisfaire les multiples besoins de nos clients.

UNSERE PRODUKTION

Jeder Artikel wird strengen Funktions- und Haltbarkeitstests unterzogen. Die Herstellungsverfahren, die zu einem großen Teil manuell sind, erlauben es, die besten Techniken im industriellen Handwerk zu entwickeln, und unsere Qualitätskontrolle basiert auf höchsten Standards.

Unser internes Technikbüro, das sich um die Entwicklung der Produkte kümmert, kann auch für die Bedürfnisse der Kunden maßgefertigte Artikel schaffen. Unsere interne Projektabteilung gestaltet in Zusammenarbeit mit italienischen und ausländischen Designern Produkte, bei denen Technologie, Innovation und Design besondere Aufmerksamkeit geschenkt wird, immer der Geschichte unseres Unternehmens folgend.

CONTRACT

Si sono fidati di noi clienti privati, produttori di yacht e numerosi hotel di lusso in Italia, Spagna, Francia, Germania, Russia e Messico. I clienti apprezzano il design sofisticato, la qualità eccellente e le illimitate possibilità di adattamento dei nostri prodotti alle più svariate esigenze di design, estetiche e funzionali.

CONTRACT

Cientes privados, fabricantes de yates y numerosos hoteles de lujo en Italia, España, Francia, Alemania, Rusia, México, Emiratos Árabes Unidos etc. Los clientes aprecian el diseño sofisticado, la excelente calidad y las ilimitadas posibilidades de personalización de la nuestra gama de productos con los más variados requisitos de diseño, estética y funcionalidad.

CONTRACT

Private customers, yacht manufacturers and numerous luxury hotels in Italy, Spain, France, Germany, Russia and Mexico, United Arab Emirates. Customers appreciate the sophisticated design, excellent quality and unlimited possibilities for customization of ours products with the most varied design requirements, aesthetic and functional

CONTRACT

Privatkunden, Hersteller von Yachten und zahlreiche Luxushotels in Italien, Spanien, Frankreich, Deutschland, Russland, Mexico und in den Vereinigten Arabischen Emiraten haben ihr Vertrauen in uns gesetzt. Die Kunden schätzen das raffinierte Design, die hervorragende Qualität und die unzähligen Möglichkeiten für Spezialanfertigungen.

CONTRACT

Clients particuliers, constructeurs navals et nombreux relais de charme en Italie, Espace, France, Allemagne, Russie, Mexico et aux Emirats Arabes font confiance à nous. Nos clients aiment le design, la qualité et la possibilité de personnalisation de nos produits.



2023

Bogogno Golf Resort | Bogogno | Italy

Prodotti forniti / Supplied products

Specchi ingranditori Disco LED / Disco LED magnifying mirrors



2023

Hotel Le 2 Torri | Verona | Italy

Prodotti forniti / Supplied products

Scopini / Toilet brushes



2020

Hotel Panorama | Malosco | Italy

Prodotti forniti / Supplied products

Accessori, specchiere, asciugacapelli / Accessories, wall mirrors, phon



2020

Hotel des Voyageurs | Lausanne | Suisse

Prodotti forniti / Supplied products

Specchiere personalizzate su misura / Custom made wall mirrors



2020

Rubens Hotel | Milano | Italy

Prodotti forniti / Supplied products

Piantane attrezzate / Equipped stands



2018

Hotel San Pietro | Positano | Italy

Prodotti forniti / Supplied products

Specchi ingranditori Disco LED / Disco LED magnifying mirrors



2009-18

Baglioni Hotel | Milano | Italy

Prodotti forniti / Supplied products

Accessori 4Quattro / 4Quattro accessories



2017

Hilton Lake | Como | Italy

Prodotti forniti / Supplied products

Specchiere ambiente Disco LED / Mirrors with LED room light







MATERIA p. 38
STRESA p. 92

REVERSO PLUS p.80
SEDILE 1 p.72

SGABELLO p.76
GRIGLIA p.70





WATSON p. 104
BELLAGIO p. 94

LEM 2.T p.46
SEDILE 2 p.74

SGABELLO p.76
GRIGLIA p.70





WATSON

p. 104

TITO

p. 28

VINTAGE

p.100





ACCESSORI

ACCESORIOS DE PARED

WALL ACCESSORIES

ZUBEHÖR FÜR WANDMONTAGE

ACCESSOIRES À FIXER





PIEGA

Design: ErvasBasilicoGirardi



N



V

Applicazione a tassello

Se instala con taladro
Installation with plug
Anbringen mit Dübel
Accessoires à percer

Nottolino coprivite

Screw cover
Tapa atornillada
Couvercle à vis
Schraubdeckel

Taglio laser

Laser cut
Corte láser
Découpe laser
Laserschnitt

Acciaio verniciato epoxi nero/bianco opaco

Acero pintado epoxi negro/blanco mate
Matt black/white epoxy painted steel
Mattschwarzer/Mattweiss, epoxylackierter Stahl
Acier peint époxy noir/blanc mat

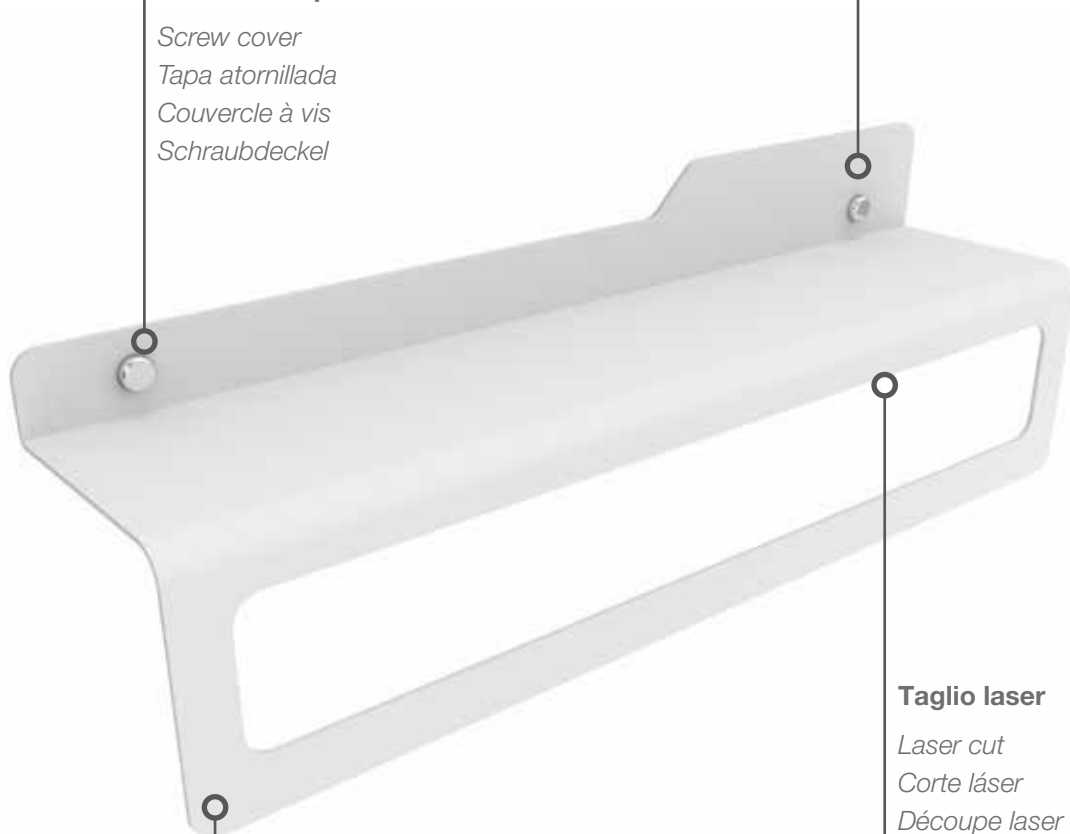



PIEGA

Design: ErvasBasilicoGirardi

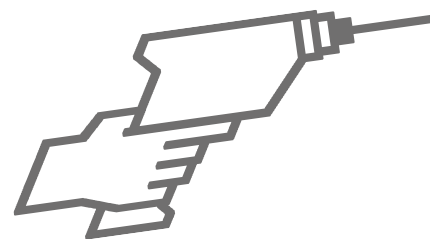

N

V



Porta salviette con mensola integrata

Repisa con toallero // Towel rack with integrated shelf
// Handtuchhalter mit integrierter Ablage //
Porte-serviettes avec étagère intégrée

cm 45 x 10 x h 15.2

Art. 7530V

Art. 7530N



Griglia doccia rettangolare

Contenedor rectangular // Shower basket // Ablage //
Panier

cm 25 x 10 x h 7.4

Art. 7519V

Art. 7519N



Porta salviette 33

Toallero 33 // Wall towel rack 33 // Handtuchhalter 33
// Porte-serviette 33

cm 33 x 6.2 x h 4.4

Art. 7507V

Art. 7507N



Griglia doccia angolare

Contenedor angular // Angular shower basket //
Ablage // Panier

cm 18.8 x 18.8 x h 7.4

Art. 7520V

Art. 7520N



Appendi abiti triplo con mensola

Repisa con colgador triple // Triple Hook with shelf //
Dreifachhaken mit Ablage // Patère triple avec étagère

cm 33 x 10 x h 11

Art. 7500V

Art. 7500N



Porta salviette 45

Toallero 45 // Wall towel rack 45 // Handtuchhalter 45
// Porte-serviette 45

cm 45 x 6.2 x h 4.4

Art. 7504V

Art. 7504N



Porta rotolo con mensola

Portarollos con repisa // Wall toilet paper with shelf
// Rollenhalter mit Ablage // Porte-rouleau de papier
toilette avec étagère

cm 19 x 11 x h 9.6

Art. 7508V

Art. 7508N



Mensola sotto specchio

(bicchiere/dispenser esclusi)

Repisa espejo (vaso y dispensador excluidos) // Mirror
shelf (glass and soap dispenser not included) // Ablage
unter Spiegel (ohne Getränkehalter / Spender) //
Étagère sous miroir (porte-gobelet/distributeur exclus)

cm 52 x 8.7 x h 6.6

Art. 7531V

Art. 7531N



Contenitore a parete

Contenedor box // Wall container // Wandbox //
Conteneur mural

cm 45.6 x 10 x h 25.2

Art. 7532V

Art. 7532N



Griglia doppia doccia rettangolare
 Contenedor doble // Hanging double shower Basket //
 Doppelte Ablage // Panier double
 cm 25 x 10 x h 75
 Art. 7522V
 Art. 7522N



Scopino sospeso
 Escobillero de pared // Wall toilet brush holder //
 Toilettenbürste Wandmodell // Porte-balai mural
 cm 9,5 x 9,5 x h 55
 Art. 7511V
 Art. 7511N

Scopino a terra
 Escobillero de suelo // Toilet brush holder //
 Toilettenbürste // Porte-balai
 cm 9,5 x 9,5 x h 55
 Art. 7512V
 Art. 7512N

TITO

Design: Studio KOH-I-NOOR



KK



N

Bicchiere e portasapone: vetro acidato

Vaso y jabonera: vidrio al ácido

Glass and soap holder: acidified glass

Glas, Seifenhalter: gesäuertes Kristallglas

Verre, porte-savon: verre acidé



Applicazione a tassello

Se instala con taladro

Installation with plug

Anbringen mit Dübel

Accessoires à percer



Viteria: acciaio inox.

Tornillería: acero inoxidable.

Fittings: stainless steel

Schrauben: Edelstahl

Visserie: acier inox.

Ottone pieno cromato o nero opaco.

Latón macizo cromado o negro mate.

Chromed or black mat full brass.

Massives Messing, verchromt oder matt schwarz.

Laiton massif chromé ou noir mat.



TITO



Supporto + Portasapone vetro acidato

Soporte para accesorios + Jabonera cristal al ácido // Support for accessories + Soap holder-acidified glass // Halterung für Accessoires + Wandseifenschale-gesäuertes Kristallglas // Support pour accessoires + Porte-savon cristal acidé.

cm 14,7 x 11,7 x h 4,2

Art. 7417KK

Art. 7417N



Supporto + Bicchieri vetro acidato

Soporte para accesorios + Portavasos cristal al ácido // Support for accessories + Cup acidified glass // Halterung für Accessoires + Wandbecher gesäuertes Kristallglas // Support pour accessoires + Verre cristal acidé

cm 12,7 x 9,8 x h 11,7

Art. 7418KK

Art. 7418N



Appendino

Colgador // Hanger // Haken // Patère

cm 3,5 x 5,3 x h 3,8

Art. 7400KK

Art. 7400N

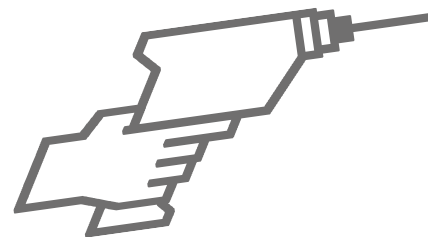

Portasalvietta

Toallero // Towel rack // Handtuchhalter // Porteserviette

cm 33 x 7 x h 3,5

Art. 7407KK

Art. 7407N



Portasalvietta

Toallero // Towel rack // Handtuchhalter // Porteserviette

cm 48 x 7 x h 3,5

Art. 7404KK

Art. 7404N



Portasalvietta

Toallero // Towel rack // Handtuchhalter // Porteserviette

cm 63 x 7 x h 3,5

Art. 7409KK

Art. 7409N



Portarotolo

Portarrollos // Paper holder // Rollenhalter // Porteserviettes

cm 17,8 x 7 x h 3,5

Art. 7408KK

Art. 7408N



Portarotolo riserva

Portarrollos de reserva // Reserve paper holder // Reserverollenhalter // Porteserviettes de réserve

cm 3,5 x 7 x h 14,5

Art. 7410KK



Portasalvietta

Toallero // Towel rack // Handtuchhalter // Porteserviette

cm 32 x 3,5 x h 3,5

Art. 7406KK



Kit 4 pezzi (7400x2 + 7404 + 7408)

Conjunto de 4 piezas // Kit 4 pieces // Set 4 Teile // Kit 4 pièces

cm 55 x 18,5 x 8,5

Art. 74SET-KK

Art. 74SET-N



Mensola portasalvietta

Toallero estante // Towel shelf // Handtuchablage // Étagère porteserviettes

cm 48,5 x 27 x h15

Art. 8902G



Art. 8902GN



Scopino sospeso

Escobillero de pared // Wall toilet brush holder // Toilettenbürste Wandmodell // Porte-balai mural
cm 9,5 x 9,5 x h 55

Art. 7411KK

Art. 7411N

Scopino a terra

Escobillero de suelo // Toilet brush holder // Toilettenbürste // Porte-balai
cm 9,5 x 9,5 x h 55

Art. 6112KK

Art. 6112N



Cestino contenitore

Contenedor // Container // Ablage // Panier
cm 23,9 x 10,5 x h 8

Art.

45809



Cestino contenitore

Contenedor // Container // Ablage // Panier
cm 19 x 19 x h 8

Art.

45806

TRATTO

Design: Itamar Harari



S

Applicazione a tassello

Se instala con taladro
Installation with plug
Anbringen mit Dübel
Accessoires à percer

Bicchieri e portasapone in policarbonato

Vaso y jabonera: policarbonato
Glass and soap holder: transparent polycarbonate
Glas, Seifenhalter: transparentes Polykarbonat
Verre, porte-savon: polycarbonate transparent



Acciaio inox AISI 304 spazzolato

AISI 304 acero inoxidable cepillado mate
AISI 304 brushed stainless steel
Gebürsteter Edelstahl AISI 304
Acier inox AISI 304 brossé

Applicazione con adesivo 3M

Se instala con adhesivo 3M
Installation with adhesive 3M
Anbringen mit 3M Klebeband
Application avec adhésif 3M



Viteria: acciaio inox.

Tornillería: acero inoxidable.
Fittings: stainless steel
Schrauben: Edelstahl
Visserie: acier inox.



TRATTO

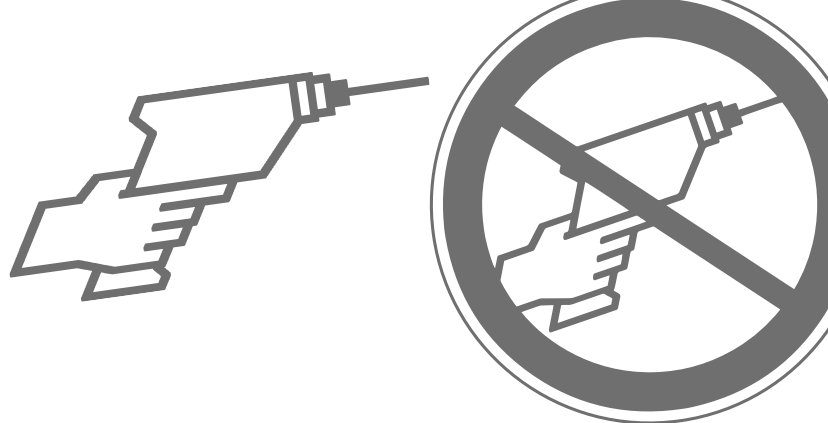

Portasapone policarbonato

Jabonera policarbonato // Soap holder - polycarbonate // Wandseifenschale-Polykarbonat // Porte-savon polycarbonate

cm 13 x 10,5 x h 4

Art. 7117S



Appendino

Colgador // Hanger // Haken // Patère

ø cm 1,2 x 4,1

Art. 7100S



Portasalvietta

Toallero // Towel rack // Handtuchhalter // Porteserviette

cm 32 x 7,2 x h 1,2

Art. 7107S



Bicchiera policarbonato

Portavasos policarbonato // Cup-polycarbonate // Wandbecher-Polykarbonat // Verre polycarbonate

cm 11 x 10 x h 12

Art. 7118S



Portarotolo

Portarollos // Paper holder // Rollenhalter // Porteroileaux

ø cm 1,2 / 2 x 12

Art. 7110S



Portasalvietta

Toallero // Towel rack // Handtuchhalter // Porteserviette

cm 45 x 7,2 x h 1,2

Art. 7104S



Dispenser policarbonato

Dosificador policarbonato // Soap dispenser-polycarbonate // Wandseifenspender-Polykarbonat // Doseur polycarbonate

cm 11 x 10 x h 19

Art. 7114S



Portarotolo

Portarollos // Paper holder // Rollenhalter // Porteroileaux

cm 14,4 x 14,7 x h 2

Art. 7108S

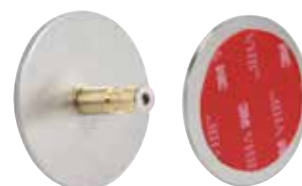

Supporto adesivo

Soporte adhesivo // Adhesive support // Klebehalterung // Support adhésif

ø cm 5

Art. 7198S



VIDEO INSTRUCTIONS



Scopino sospeso

*Escobillero de pared // Wall toilet brush holder //
Toilettenbürste Wandmodell // Porte-balai mural*

ø cm 8 x h 43

Art. 7111S

Scopino a terra

*Escobillero de suelo // Toilet brush holder //
Toilettenbürste // Porte-balai*

ø cm 8 x h 43

Art. 7112S

LAVÍ

Design: Studio KOH-I-NOOR + Monica Cerina



KK



V



T



V

Bicchieri e portasapone in policarbonato

Vaso y jabonera: policarbonato
Glass and soap holder: transparent polycarbonate
Glas, Seifenhalter: transparentes Polykarbonat
Verre, porte-savon: polycarbonate transparent

Applicazione con adesivo 3M

Se instala con adhesivo 3M
Installation with adhesive 3M
Anbringen mit 3M Klebeband
Application avec adhésif 3M



Acciaio inox cromato, ottone cromato o bianco opaco

Acero inox cromado, latón cromado o blanco mate
Chromed stainless steel, chromed brass, matt white
Verchromter Edelstahl, verchromtes Messing, Mattweiß
Acier inox chromé, laiton chromé, blanc mat



KK



V

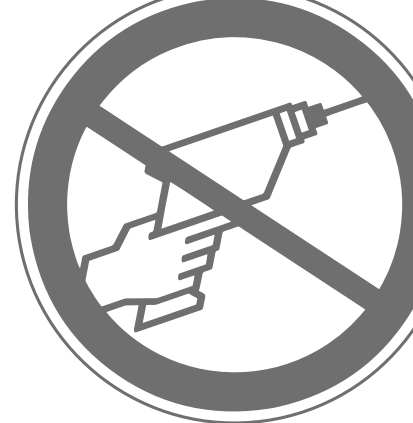

Portasapone da parete in policarbonato

Jabonera de pared-policarbonato // Wall soap holder - polycarbonate // Wandseifenschale-Polykarbonat // Porte-savon mural-polycarbonate

cm 9 x 14,5 x h 4,5

Art. K830T

Art. K830V



Bicchieri da parete in policarbonato

Portavasos de pared-policarbonato // Wall cup-polycarbonate // Wandbecher-Polykarbonat // Verre mural-polycarbonate // Doseur mural-polycarbonate

cm 8,5 x 5,5 x h 12

Art. K838T

Art. K838V



Dispenser da parete in policarbonato

Dosificador de pared-policarbonato // Wall soap dispenser-polycarbonate // Wandseifenspender-Polykarbonat // Doseur mural-polycarbonate

cm 8,5 x 5,5 x h 16,5

Art. K857T

Art. K857V



Portasalviette

Toallero // Towel rack // Handtuchhalter // Porteserviette

cm 35 x 6 x h 6,5

Art. 5907KK

Art. 5907V



Portasalviette

Toallero // Towel rack // Handtuchhalter // Porteserviette

cm 45 x 6 x h 6,5

Art. 5904KK

Art. 5904V



Portasalviette

Toallero // Towel rack // Handtuchhalter // Porteserviette

cm 60 x 6 x h 6,5

Art. 5909KK

Art. 5909V



Cestino contenitore

Contenedor // Container // Ablage // Panier

cm 35 x 10 x h 8

Art. 5921KK



Cestino contenitore

Contenedor // Container // Ablage // Panier

cm 27 x 19 x h 8

Art. 5920KK



Cestino contenitore

Contenedor // Container // Ablage // Panier

cm 25 x 10 x h 8

Art. 5919KK



VIDEO INSTRUCTIONS

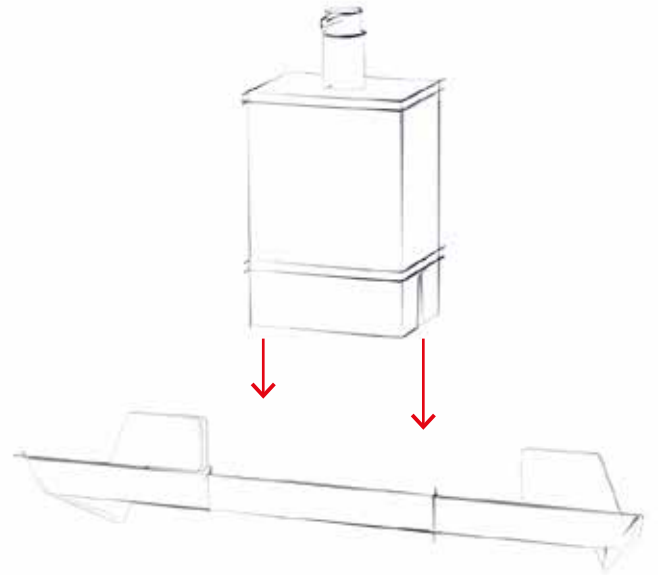

Appendino

Colgador // Hanger // Haken // Patère

cm 5,4 x 4 x h 6,3

Art. 5900KK

Art. 5900V



Appendino doppio

Colgador doble // Double hanger // Doppelter Haken // Patère double

cm 10,5 x 4 x h 6,3

Art. 5916KK

Art. 5916V



Portasalviette

Toallero // Towel rack // Handtuchhalter // Porte-serviette

cm 23,3 x 6 x h 6,5

Art. 5924KK

Art. 5924V



Portarrotolo / supporto per accessori

Portarrollos / Soporte para accesorios // Paper holder / Support for accessories // Rollenhalter / Halterung für Accessoires // Porte-rouleaux / Support pour accessoires

cm 14 x 6 x h 6,5

Art. 5908KK

Art. 5908V



Scopino sospeso

Escobillero de pared // Wall toilet brush holder // Toilettenbürste Wandmodell // Porte-balai mural

cm 9,5 x 9,5 x h 55

Art. 7511KK + 7498

Art. 7511V + 7498

Scopino a terra

Escobillero de suelo // Toilet brush holder // Toilettenbürste // Porte-balai

cm 9,5 x 9,5 x h 55

Art. 7512KK

Art. 7512V



Kit 4 pezzi (5900x2 + 5908 + 5904)

Conjunto de 4 piezas // Kit 4 pieces // Set 4 Teile // Kit 4 pièces

cm 55 x 18.5 x 8.5

Art. 59SET-KK

Art. 59SET-V



Supporto adesivo per scopino

Soportes adhesivo para escobillero // Adhesive supports for toilet brush // Toilettenbürsten-Klebehalter // Supports adhésif pour porte balai

Art. 7498

MATERIA

Design: Studio KOH-I-NOOR



KK



V



N

Bicchieri e portasapone in policarbonato

Vaso y jabonera: policarbonato
Glass and soap holder: transparent polycarbonate
Glas, Seifenhalter: transparentes Polykarbonat
Verre, porte-savon: polycarbonate transparent



Applicazione con adesivo 3M

Se instala con adhesivo 3M
Installation with adhesive 3M
Anbringen mit 3M Klebeband
Application avec adhésif 3M



Alluminio anodizzato lucido o nero opaco / bianco opaco

Aluminio anodizado brillante, negro mate/blanco mate
Anodized shiny aluminium matt black/matt white
Glänzendes eloxiertes Aluminium Mattschwarz/Mattweiß
Aluminium brillant éloxé noir mat/blanc mat



MATERIA

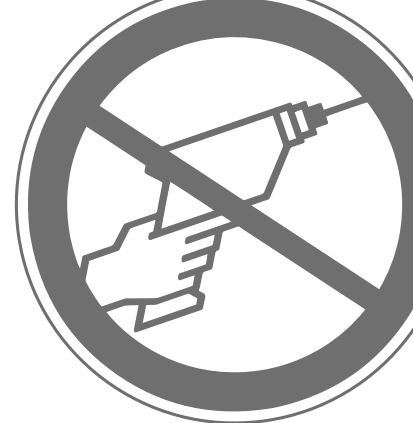

Portasapone policarbonato

Jabonera policarbonato // Soap holder - polycarbonate // Wandseifenschale-Polykarbonat // Porte-savon polycarbonate

cm 11,5 x 13 x h 7,5

Art. 6017KK

Art. 6017V

Art. 6017N



Portasalviette

Toallero // Towel rack // Handtuchhalter // Porteserviette

cm 32 x 7,6 x h 3

Art. 6007KK

Art. 6007V

Art. 6007N



Appendino

Colgador // Hanger // Haken // Patère

cm 3 x 4,6 x h 8

Art. 6000KK

Art. 6000V

Art. 6000N



Bicchiere policarbonato

Portavasos policarbonato // Cup-polycarbonate // Wandbecher-Polykarbonat // Verre polycarbonate

cm 10 x 8 x h 11

Art. 6018KK

Art. 6018V

Art. 6018N



Portasalviette

Toallero // Towel rack // Handtuchhalter // Porteserviette

cm 45 x 7,6 x h 3

Art. 6004KK

Art. 6004V

Art. 6004N



Portarotolo

Portarrotolos // Paper holder // Rollenhalter // Porteroileaux

cm 14,8 x 7,6 x h 3

Art. 6008KK

Art. 6008V

Art. 6008N



Dispenser policarbonato

Dosificador policarbonato // Soap dispenser-polycarbonate // Wandseifenspender-Polykarbonat // Doseur polycarbonate

cm 10 x 8 x h 18

Art. 6014KK

Art. 6014V

Art. 6014N



Portasalviette

Toallero // Towel rack // Handtuchhalter // Porteserviette

cm 60 x 7,6 x h 3

Art. 6009KK

Art. 6009V

Art. 6009N



Portasalviette

Toallero // Towel rack // Handtuchhalter // Porteserviette

cm 22,8 x 7,6 x h 3

Art. 6024KK

Art. 6024V

Art. 6024N



VIDEO INSTRUCTIONS



Kit 4 pezzi (6000x2 + 6008 + 6004)

Conjunto de 4 piezas // Kit 4 pieces // Set 4 Teile // Kit 4 pièces

cm 55 x 18.5 x 8.5

Art. 60SET-KK

Art. 60SET-V

Art. 60SET-N



Cestino contenitore

Contenedor // Container // Ablage // Panier

cm 27,5 x 12 x h 8

Art. 6019KK

Art. 6019V

Art. 6019N



Supporto adesivo per scopino

Soportes adhesivo para escobillero // Adhesive supports for toilet brush // Toilettenbürsten-Klebehalter // Supports adhésif pour porte balai

Art. 7498



Scopino sospeso

Escobillero de pared // Wall toilet brush holder // Toilettenbürste Wandmodell // Porte-balai mural

cm 9,5 x 9,5 x h 55

Art. 7511KK + 7498

Art. 7511V + 7498

Art. 7511N + 7498

Scopino a terra

Escobillero de suelo // Toilet brush holder // Toilettenbürste // Porte-balai

cm 9,5 x 9,5 x h 55

Art. 7512KK

Art. 7512V

Art. 7512N

LEM

Design: Studio KOH-I-NOOR e Monica Cerina



KK



T



V

Bicchieri e portasapone in policarbonato

Vaso y jabonera: policarbonato
Glass and soap holder: transparent polycarbonate
Glas, Seifenhalter: transparentes Polykarbonat
Verre, porte-savon: polycarbonate transparent



Lem 2.0 Applicazione con adesivo 3M

Se instala con adhesivo 3M
Installation with adhesive 3M
Anbringen mit 3M Klebeband
Application avec adhésif 3M

Lem 2.T Applicazione a tassello

Se instala con taladro
Installation with plug
Anbringen mit Dübel
Accessoires à percer

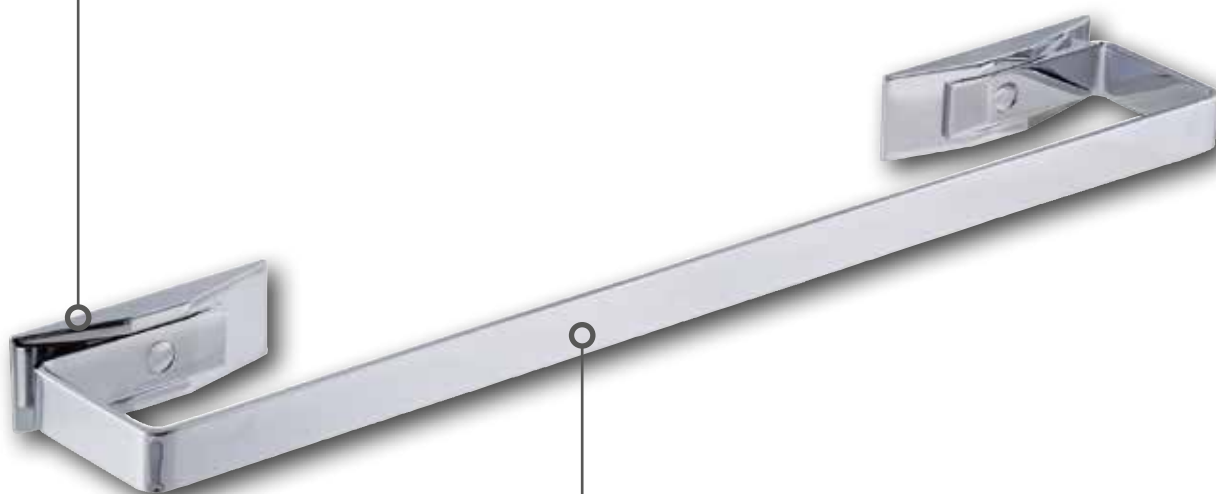

Acciaio inox cromato, ottone cromato

Acero inox cromado, latón cromado
Chromed stainless steel, chromed brass
Verchromter Edelstahl, verchromtes Messing
Acier inox chromé, laiton chromé.



LEM 2.0

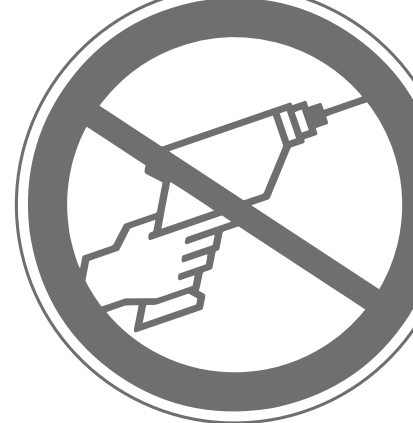

Portasapone da parete in policarbonato

Jabonera de pared-policarbonato // Wall soap holder - polycarbonate // Wandseifenschale-Polykarbonat // Porte-savon mural-polycarbonate

cm 9 x 14,5 x h 4,5

Art. K830T

Art. K830V



Bicchieri da parete in policarbonato

Portavasos de pared-policarbonato // Wall cup-polycarbonate // Wandbecher-Polykarbonat // Verre mural-polycarbonate // Doseur mural-polycarbonate

cm 8,5 x 5,5 x h 12

Art. K838T

Art. K838V



Dispenser da parete in policarbonato

Dosificador de pared-policarbonato // Wall soap dispenser-polycarbonate // Wandseifenspender-Polykarbonat // Doseur mural-polycarbonate

cm 8,5 x 5,5 x h 16,5

Art. K857T

Art. K857V



Portasalviette

Toallero // Towel rack // Handtuchhalter // Porteserviette

cm 32 x 6,5 x h 3

Art. 6207KK



Portasalviette

Toallero // Towel rack // Handtuchhalter // Porteserviette

cm 45 x 6,5 x h 3

Art. 6204KK



Portasalviette

Toallero // Towel rack // Handtuchhalter // Porteserviette

cm 60 x 6,5 x h 3

Art. 6209KK



Appendino doppio

Colgador doble // Double hanger // Doppelter Haken // Patère double

cm 8,5 x 5 x h 3

Art. 6216KK



Portarotolo / supporto per accessori

Portarrollos / Soporte para accesorios // Paper holder / Support for accessories // Rollenhalter / Halterung für Accessoires // Porte-rouleaux / Support pour accessoires

cm 11,3 x 7,5 x h 3

Art. 6208KK



Portasalviette / Portarotolo riserva

Toallero / Portarrollos de reserva // Towel rack / Reserve paper holder // Handtuchhalter / Reserverollenhalter // Porteserviette / Porte-rouleaux de réserve

cm 22 x 7,5 x h 3

Art. 6224KK



VIDEO INSTRUCTIONS



Cestino contenitore

Contenedor // Container // Ablage // Panier

cm 19 x 19 x h 31

Art. 6221KK

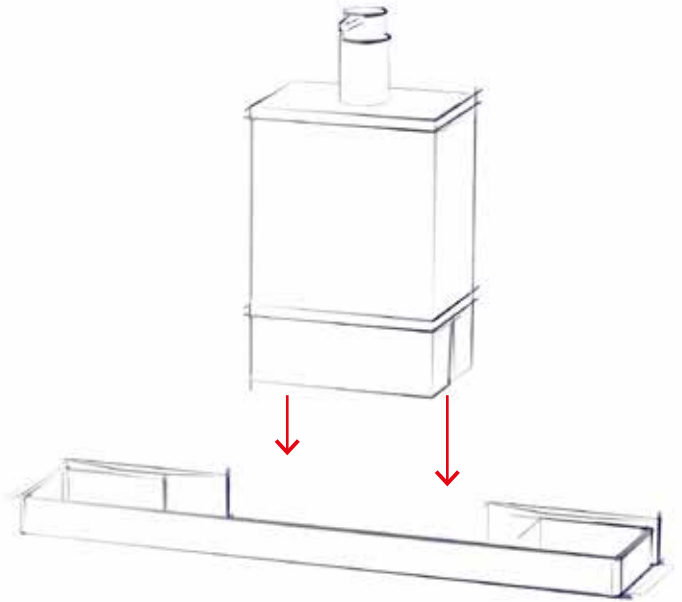

Cestino contenitore

Contenedor // Container // Ablage // Panier

cm 23,3 x 10,3 x h 8

Art. 6219KK



Cestino contenitore

Contenedor // Container // Ablage // Panier

cm 19 x 19 x h 8

Art. 6220KK



Supporto adesivo per scopino

Soportes adhesivo para escobillero // Adhesive supports for toilet brush // Toilettenbürsten-Klebehalter // Supports adhésif pour porte balai

Art. 7498



Scopino sospeso

Escobillero de pared // Wall toilet brush holder // Toilettenbürste Wandmodell // Porte-balai mural

cm 9,5 x 9,5 x h 55

Art. 7511KK + 7498

Scopino a terra

Escobillero de suelo // Toilet brush holder // Toilettenbürste // Porte-balai

cm 9,5 x 9,5 x h 55

Art.7512KK

LEM 2.T

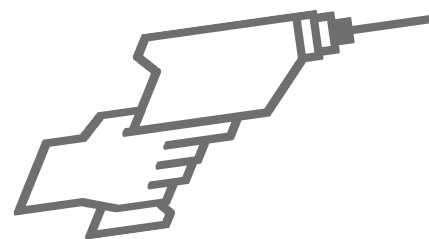

Portasapone da parete in policarbonato

Jabonera de pared-policarbonato // Wall soap holder - polycarbonate // Wandseifenschale-Polykarbonat // Porte-savon mural-polycarbonate

cm 9 x 14,5 x h 4,5

Art. K830T

Art. K830V



Bicchieri da parete in policarbonato

Portavasos de pared-policarbonato // Wall cup-polycarbonate // Wandbecher-Polykarbonat // Verre mural-polycarbonate // Doseur mural-polycarbonate

cm 8,5 x 5,5 x h 12

Art. K838T

Art. K838V



Dispenser da parete in policarbonato

Dosificador de pared-policarbonato // Wall soap dispenser-polycarbonate // Wandseifenspender-Polykarbonat // Doseur mural-polycarbonate

cm 8,5 x 5,5 x h 16,5

Art. K857T

Art. K857V



Portasalviette

Toallero // Towel rack // Handtuchhalter // Porteserviette

cm 32 x 6,5 x h 3

Art. 6307KK



Portasalviette

Toallero // Towel rack // Handtuchhalter // Porteserviette

cm 45 x 6,5 x h 3

Art. 6304KK



Portasalviette

Toallero // Towel rack // Handtuchhalter // Porteserviette

cm 60 x 6,5 x h 3

Art. 6309KK



Appendino doppio

Colgador doble // Double hanger // Doppelter Haken // Patère double

cm 8,5 x 5 x h 3

Art. 6316KK



Portarotolo / supporto per accessori

Portarrollos / Soporte para accesorios // Paper holder / Support for accessories // Rollenhalter / Halterung für Accessoires // Porte-rouleaux / Support pour accessoires

cm 11,3 x 7,5 x h 3

Art. 6308KK



Portasalviette / Portarotolo riserva

Toallero / Portarrollos de reserva // Towel rack / Reserve paper holder // Handtuchhalter / Reserverollenhalter // Porte-serviette / Porte-rouleaux de réserve

cm 22 x 7,5 x h 3

Art. 6324KK



Cestino contenitore
 Contenedor // Container // Ablage // Panier
 cm 19 x 19 x h 31
 Art. 6321KK

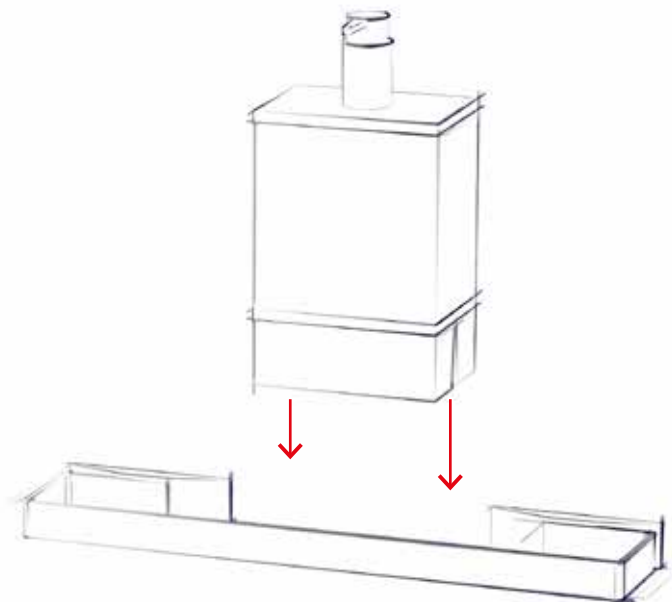

Cestino contenitore
 Contenedor // Container // Ablage // Panier
 cm 23,3 x 10,3 x h 8
 Art. 6319KK



Scopino sospeso
 Escobillero de pared // Wall toilet brush holder //
 Toilettenbürste Wandmodell // Porte-balai mural
 cm 9,5 x 9,5 x h 55

Art. 7511KK



Cestino contenitore
 Contenedor // Container // Ablage // Panier
 cm 19 x 19 x h 8
 Art. 6320KK

Scopino a terra
 Escobillero de suelo // Toilet brush holder //
 Toilettenbürste // Porte-balai
 cm 9,5 x 9,5 x h 55

Art.7512KK

TILDA

Design: Studio KOH-I-NOOR



KK

Bicchieri e portasapone in policarbonato

Vaso y jabonera: policarbonato
Glass and soap holder: transparent polycarbonate
Glas, Seifenhalter: transparentes Polykarbonat
Verre, porte-savon: polycarbonate transparent



Applicazione con adesivo 3M

Se instala con adhesivo 3M
Installation with adhesive 3M
Anbringen mit 3M Klebeband
Application avec adhésif 3M



Asta e griglie ottone cromato

Barras y rejillas: latón cromado
Bars and grids: chromed brass
Stangen und Körbchen: verchromtes Messing.
Tiges et paniers: laiton chromé.

Supporti ABS cromato

Soportes ABS cromado
Supports chromed ABS
Unterstützung verchromtes ABS
Supports ABS chromé





Appendino (2 pezzi)

Colgador 2pz // Hanger 2pz // Haken 2st // Patère 2pcs

cm 5,5 x 4,5 x h 5,5

Art. 5700KK



Portarotolo

Portarrollos // Paper holder // Rollenhalter // Porte-rouleaux

cm 16 x 7 x h 5,5

Art. 5708KK



Portasalviette / Portarotolo riserva

Toallero / Portarrollos de reserva // Towel rack / Reserve paper holder // Handtuchhalter / Reserverollenhalter // Porte-serviette / Porte-rouleaux de réserve

cm 25,5 x 7 x h 5,5

Art. 5710KK



Portasalviette

Toallero // Towel rack // Handtuchhalter // Porte-serviette

cm 36 x 7 x h 5,5

Art. 5707KK



Portasalviette

Toallero // Towel rack // Handtuchhalter // Porte-serviette

cm 52 x 7 x h 5,5

Art. 5704KK



Portasalviette a snodo

Toallero giratorio // Turning towel rack // Schwenkbarer Handtuchhalter // Porte-serviette pivotant

cm 33 x 5,5 x h 12

Art. 5706KK



Portasapone policarbonato

Jabonera policarbonato // Soap holder - polycarbonate // Wandseifenschale-Polykarbonat // Porte-savon polycarbonate

cm 13 x 10,5 x h 5,5

Art. 5717KK



Bicchieri policarbonato

Portavasos policarbonato // Cup-polycarbonate // Wandbecher-Polykarbonat // Verre polycarbonate

cm 8 x 9,5 x h 13,5

Art. 5718KK



Dispenser policarbonato

Dosificador policarbonato // Soap dispenser-polycarbonate // Wandseifenspender-Polykarbonat // Doseur polycarbonate

cm 8 x 9,5 x h 20

Art. 5714KK



Supporto adesivo per scopino

Soportes adhesivo para escobillero // Adhesive supports for toilet brush // Toilettenbürsten-Klebehalter // Supports adhésif pour porte balai

Art. 7498



Scopino sospeso

Escobillero de pared // Wall toilet brush holder // Toilettenbürste Wandmodell // Porte-balai mural

cm 9,5 x 9,5 x h 55

Art. 7511KK + 7498

Scopino a terra

Escobillero de suelo // Toilet brush holder // Toilettenbürste // Porte-balai

cm 9,5 x 9,5 x h 55

Art. 7512KK



VIDEO INSTRUCTIONS



Supporto per cestini

Soportes para contenedor // Supports for container // Klebehalterungen // Supports pour panier

cm 5,5 x 1,5 x 5,5

Art. 5798KK



Cestino contenitore

Contenedor // Container // Ablage // Panier

cm 23,3 x 12 x h 7,5/5

Art. 5719KK



Cestino contenitore

Contenedor // Container // Ablage // Panier

cm 19 x 19 x h 8/11,7

Art. 45806

Art. 5798KK

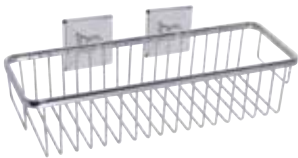

Cestino contenitore

Contenedor // Container // Ablage // Panier

cm 45 x 12 x h 8/11,7

Art. 45808

Art. 5798KK



Cestino contenitore

Contenedor // Container // Ablage // Panier

cm 23,3 x 10,3 x h 8/11,7

Art. 45809

Art. 5798KK

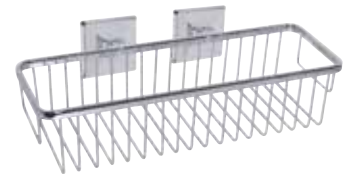

Cestino contenitore

Contenedor // Container // Ablage // Panier

cm 35 x 12 x h 8/11,7

Art. 45807

Art. 5798KK



Cestino contenitore

Contenedor // Container // Ablage // Panier

cm 19 x 19 x h 31/34,7

Art. 45803

Art. 5798KK



Kit 4 pezzi (5700 + 5704 + 5708)

Conjunto de 4 piezas // Kit 4 pieces // Set 4 Teile // Kit 4 pièces

cm 55 x 18,5 x 8,5

Art. 57SET-KK

10

Design: Studio KOH-I-NOOR



KK

Bicchieri e portasapone in policarbonato

Vaso y jabonera: policarbonato
Glass and soap holder: transparent polycarbonate
Glas, Seifenhalter: transparentes Polykarbonat
Verre, porte-savon: polycarbonate transparent



Applicazione con adesivo 3M

Se instala con adhesivo 3M
Installation with adhesive 3M
Anbringen mit 3M Klebeband
Application avec adhésif 3M



Asta e griglie ottone cromato

Barras y rejillas: latón cromado
Bars and grids: chromed brass
Stangen und Körbchen: verchromtes Messing.
Tiges et paniers: laiton chromé.

Supporti ABS cromato

Soportes ABS cromado
Supports chromed ABS
Unterstützung verchromtes ABS
Supports ABS chromé



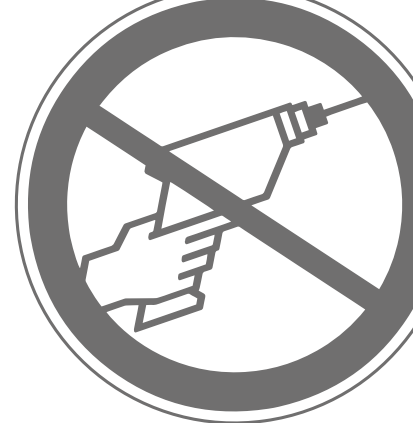

Appendino
Colgador // Hanger // Haken // Patère
ø cm 7,5 x 5
Art. 6100KK



Portarotolo
Portarrollos // Paper holder // Rollenhalter // Porte-rouleaux
cm 13,5 x 6 x h 10
Art. 6108KK



Portasalvietta
Toallero // Towel rack // Handtuchhalter // Porte-serviette
cm 39 x 6 x h 7,5
Art. 6107KK



Portasalvietta
Toallero // Towel rack // Handtuchhalter // Porte-serviette
cm 56 x 6 x h 7,5
Art. 6104KK



Portasalvietta a snodo
Toallero giratorio // Turning towel rack // Schwenkbarer Handtuchhalter // Porte-serviette pivotant
cm 34 x 7,5 x h 7,5
Art. 6106KK



Portasapone policarbonato
Jabonera policarbonato // Soap holder polycarbonate // Wandseifenschale-Polykarbonat // Porte-savon polycarbonate
cm 13 x 9,5 x h 7,5
Art. 6117KK



Bicchieri policarbonato
Portavasos policarbonato // Cup polycarbonate // Wandbecher-Polykarbonat // Verre polycarbonate
cm 7,5 x 9 x h 15
Art. 6118KK



Dispenser policarbonato
Dosificador policarbonato // Soap dispenser polycarbonate // Wandseifenspender-Polykarbonat // Doseur polycarbonate
cm 7,5 x 9 x h 20
Art. 6114KK



Supporto adesivo per scopino
Soportes adhesivo para escobillero // Adhesive supports for toilet brush // Toilettenbürsten-Klebehalter // Supports adhésif pour porte balai
Art. 7498



Scopino sospeso
Escobillero de pared // Wall toilet brush holder // Toilettenbürste Wandmodell // Porte-balai mural
cm 9,5 x 9,5 x h 55
Art. 7411KK + 7498

Scopino a terra
Escobillero de suelo // Toilet brush holder // Toilettenbürste // Porte-balai
cm 9,5 x 9,5 x h 55
Art. 6112KK



VIDEO INSTRUCTIONS



Supporto per cestini

Soportes para contenedor // Supports for container // Klebehalterungen // Supports pour panier

ø cm 7,5 x 1,5

Art. 6198KK



Cestino contenitore

Contenedor // Container // Ablage // Panier

cm 19 x 19 x h 8/11,7

Art. 45806

Art. 6198KK



Mensola portasalviette

Toallero estante // Towel shelf // Handtuchablage // Étagère porte-serviettes

cm 50 x 29 x h 20

Art. 45811

Art. 6198KK x 2



Cestino contenitore

Contenedor // Container // Ablage // Panier

cm 23,3 x 10,3 x h 8/11,7

Art. 45809

Art. 6198KK



Cestino contenitore

Contenedor // Container // Ablage // Panier

cm 23,3 x 10,3 x h 5/8,7

Art. 45802

Art. 6198KK

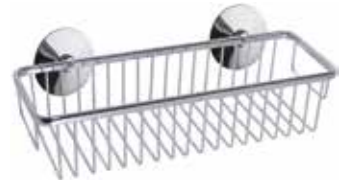

Cestino contenitore

Contenedor // Container // Ablage // Panier

cm 35 x 12 x h 8/11,7

Art. 45807

Art. 6198KK



Cestino contenitore

Contenedor // Container // Ablage // Panier

cm 19 x 19 x h 31/34,7

Art. 45803

Art. 6198KK



Cestino contenitore

Contenedor // Container // Ablage // Panier

cm 45 x 12 x h 8/11,7

Art. 45808

Art. 6198KK

TUBINA / TUBINA.T

Design: Studio KOH-I-NOOR e Monica Cerina



KK

Bicchiere e portasapone in policarbonato

Vaso y jabonera: policarbonato

Glass and soap holder: transparent polycarbonate

Glas, Seifenhalter: transparentes Polykarbonat

Verre, porte-savon: polycarbonate transparent



Applicazione a tassello

Se instala con taladro

Installation with plug

Anbringen mit Dübel

Accessoires à percer

Applicazione con adesivo 3M

Se instala con adhesivo 3M

Installation with adhesive 3M

Anbringen mit 3M Klebeband

Application avec adhésif 3M

Ottone cromato

Latón cromado

Chromed brass

Messing verchromt

Laiton chromé

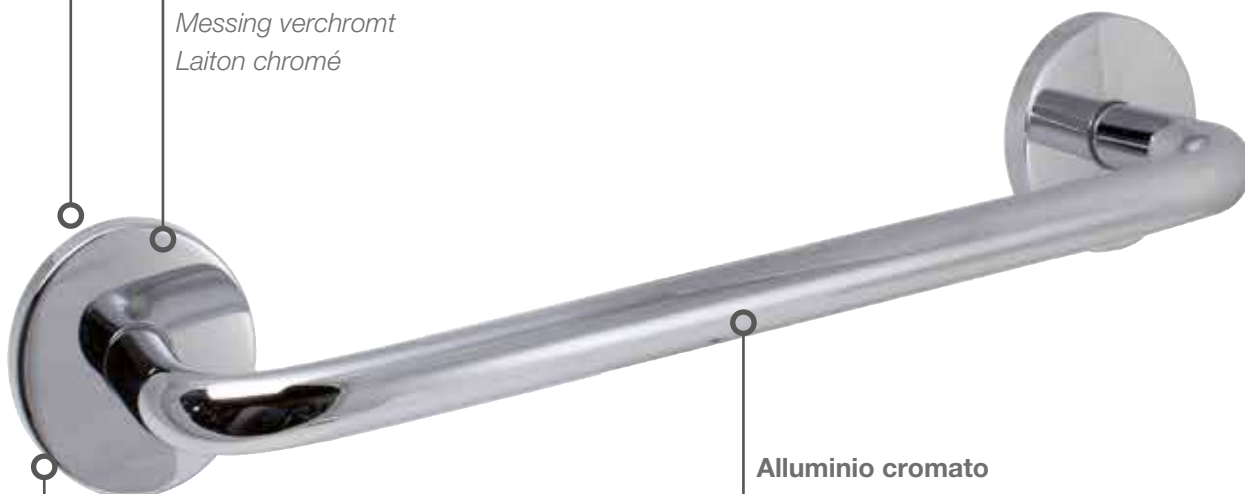

Alluminio cromato

Aluminio cromado

Chromed aluminium

Verchromtes Aluminium

Aluminium chromé

Viteria: acciaio inox

Tornillería: acero inoxidable

Fittings: stainless steel

Schrauben: Edelstahl

Visserie: acier inox



TUBINA

Applicazione a tassello

Se instala con taladro
Installation with plug
Anbringen mit Dübel
Accessoires à percer

Applicazione con adesivo 3M

Se instala con adhesivo 3M
Installation with adhesive 3M
Anbringen mit 3M Klebeband
Application avec adhésif 3M

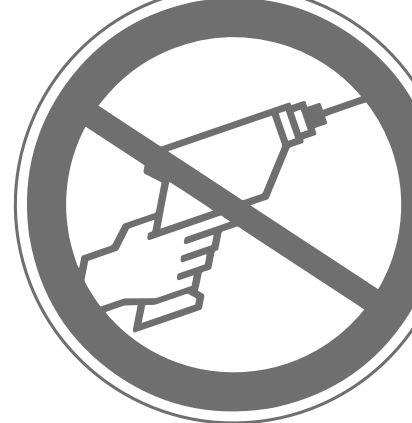
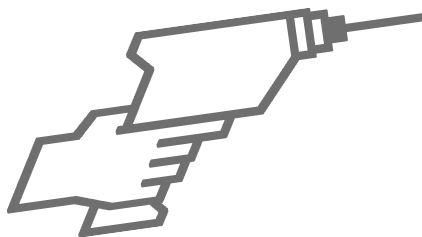

Supporto + Bicchiere policarbonato

Soporte para accesorios + Portavasos policarbonato
// Support for accessories + Cup polycarbonate
// Halterung für Accessoires + Wandbecher
Polykarbonat // Support pour accessoires + verre
polycarbonate

cm 10 x 9 x h 17

Art. 6815KK

Art. K638



Supporto + Dispenser policarbonato

Soporte para accesorios + Dosificador policarbonato
// Support for accessories + Soap dispenser
polycarbonate // Halterung für Accessoires +
Wandseifenspender Polykarbonat // Support pour
accessoires + Doseur polycarbonate

cm 10 x 9 x h 23,5

Art. 6815KK

Art. K657



Supporto + Portasapone policarbonato

Soporte para accesorios + Jabonera policarbonato
// Support for accessories + Soap holder polycarbonate
// Halterung für Accessoires + Wandseifenschale-
Polykarbonat // Support pour accessoires + Porte-
savon polycarbonate

cm 13 x 9 x h 8,5

Art. 6815KK

Art. K630



Supporto + Bicchiere vetro acidato

Soporte para accesorios + Portavasos cristal al ácido
// Support for accessories + Cup-acidified glass
// Halterung für Accessoires + Wandbecher-gesäuertes
Kristallglas // Support pour accessoires + Verre cristal
acidé

cm 10 x 9 x h 17

Art. 6815KK

Art. K938



Supporto + Dispenser vetro acidato

Soporte para accesorios + Dosificador cristal al
ácido // Support for accessories + Soap dispenser
acidified glass // Halterung für Accessoires +
Wandseifenspender-gesäuertes Kristallglas // Support
pour accessoires + Doseur cristal acidé

cm 10 x 9 x h 23,5

Art. 6815KK

Art. K957



Supporto + Portasapone vetro acidato

Soporte para accesorios + Jabonera cristal al ácido
// Support for accessories + Soap holder acidified glass
// Halterung für Accessoires + Wandseifenschale-
gesäuertes Kristallglas // Support pour accessoires
+ Porte-savon cristal acidé.

cm 13 x 9 x h 8,5

Art. 6815KK

Art. K930



Appendino

Colgador // Hanger // Haken // Patère

ø cm 6 x 4,5

Art. 6800KK



Portarotolo

Portarrollos // Paper holder // Rollenhalter // Porte-
rouleaux

cm 20 x 8 x h 6

Art. 6808KK



Portasalvietta / Portarotolo riserva

Toallero / Portarrollos de reserva // Towel rack
/ Reserve paper holder // Handtuchhalter /
Reserverollenhalter // Porte-serviette / Porte-rouleaux
de réserve

cm 25 x 8 x h 6

Art. 6824KK



VIDEO INSTRUCTIONS



Portasalvietta

Toallero // Towel rack // Handtuchhalter // Porte-serviette

cm 36 x 8 x h 6

Art. 6807KK



Portasalvietta

Toallero // Towel rack // Handtuchhalter // Porte-serviette

cm 49 x 8 x h 6

Art. 6804KK



Portasalvietta

Toallero // Towel rack // Handtuchhalter // Porte-serviette

cm 64 x 8 x h 6

Art. 6809KK



Portasalvietta a snodo

Toallero giratorio // Turning towel rack // Schwenkbarer Handtuchhalter // Porte-serviette pivotant

cm 36 x 6 x h 14

Art. 6806KK



Kit 4 pezzi (6800x2 + 6808 + 6804)

Conjunto de 4 piezas // Kit 4 pieces // Set 4 Teile // Kit 4 pièces

cm 55 x 18.5 x 8.5

Art. 68SET-KK



Scopino sospeso

Escobillero de pared // Wall toilet brush holder // Toilettenbürste Wandmodell // Porte-balai mural

cm 9,5 x 9,5 x h 55

Art. 7411KK + 7498

Scopino a terra

Escobillero de suelo // Toilet brush holder // Toilettenbürste // Porte-balai

cm 9,5 x 9,5 x h 55

Art. 6112KK



Supporto adesivo per scopino

Soportes adhesivo para escobillero // Adhesive supports for toilet brush // Toilettenbürsten-Klebehalter // Supports adhésif pour porte balai

Art. 7498

TUBINA.T

Applicazione a tassello

Se instala con taladro
Installation with plug
Anbringen mit Dübel
Accessoires à percer

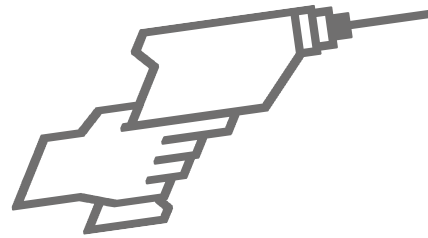

Supporto + Bicchiere policarbonato

Soporte para accesorios + Portavasos policarbonato
// Support for accessories + Cup polycarbonate
// Halterung für Accessoires + Wandbecher
Polykarbonat // Support pour accessoires + Verre
polycarbonate

cm 10 x 9 x h 17

Art. 6915KK

Art. K638



Supporto + Dispenser policarbonato

Soporte para accesorios + Dosificador policarbonato
// Support for accessories + Soap dispenser
polycarbonate // Halterung für Accessoires +
Wandseifenspender Polykarbonat // Support pour
accessoires + Doseur polycarbonate

cm 10 x 9 x h 23,5

Art. 6915KK

Art. K657



Supporto + Portasapone policarbonato

Soporte para accesorios + Jabonera policarbonato //
Support for accessories + Soap holder - polycarbonate
// Halterung für Accessoires + Wandseifenschale-
Polykarbonat // Support pour accessoires + Porte-
savon polycarbonate

cm 13 x 9 x h 8,5

Art. 6915KK

Art. K630



Supporto + Bicchiere vetro acidato

Soporte para accesorios + Portavasos cristal al ácido
// Support for accessories + Cup acidified glass //
Halterung für Accessoires + Wandbecher gesäuertes
Kristallglas // Support pour accessoires + Verre cristal
acidé

cm 10 x 9 x h 17

Art. 6915KK

Art. K938



Supporto + Dispenser vetro acidato

Soporte para accesorios + Dosificador cristal al
ácido // Support for accessories + Soap dispenser
acidified glass // Halterung für Accessoires +
Wandseifenspender gesäuertes Kristallglas // Support
pour accessoires + Doseur cristal acidé

cm 10 x 9 x h 23,5

Art. 6915KK

Art. K957

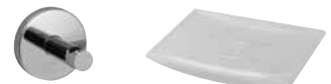

Supporto + Portasapone vetro acidato

Soporte para accesorios + Jabonera cristal al ácido //
Support for accessories + Soap holder acidified glass
// Halterung für Accessoires + Wandseifenschale-
gesäuertes Kristallglas // Support pour accessoires
+ Porte-savon cristal acidé.

cm 13 x 9 x h 8,5

Art. 6815KK

Art. K930



Appendino

Colgador // Hanger // Haken // Patère

ø cm 6 x 4,5

Art.6900KK



Portarotolo

Portarrollos // Paper holder // Rollenhalter // Porte-
rouleaux

cm 20 x 8 x h 6

Art. 6908KK



Portasalvietta / Portarotolo riserva

Toallero / Portarrollos de reserva // Towel rack
/ Reserve paper holder // Handtuchhalter /
Reserverollenhalter // Porte-serviette / Porte-rouleaux
de réserve

cm 25 x 8 x h 6

Art. 6924KK



Portasalviette

Toallero // Towel rack // Handtuchhalter // Porte-serviette

cm 36 x 8 x h 6

Art. 6907KK



Portasalviette

Toallero // Towel rack // Handtuchhalter // Porte-serviette

cm 49 x 8 x h 6

Art. 6904KK



Portasalviette

Toallero // Towel rack // Handtuchhalter // Porte-serviette

cm 64 x 8 x h 6

Art. 6909KK



Portasalviette a snodo

Toallero giratorio // Turning towel rack // Schwenkbarer Handtuchhalter // Porte-serviette pivotant

cm 36 x 6 x h 14

Art. 6906KK



Scopino sospeso

Escobillero de pared // Wall toilet brush holder // Toilettenbürste Wandmodell // Porte-balai mural

cm 9,5 x 9,5 x h 55

Art. 7411KK

Scopino a terra

Escobillero de suelo // Toilet brush holder // Toilettenbürste // Porte-balai

cm 9,5 x 9,5 x h 55

Art. 6112KK

4QUATTRO

Design: Studio KOH-I-NOOR



KK

Bicchieri e portasapone: vetro acidato

Vaso y jabonera: vidrio al ácido

Glass and soap holder: acidified glass

Glas, Seifenhalter: gesäuertes Kristallglas

Verre, porte-savon: verre acidé



Applicazione a tassello

Se instala con taladro

Installation with plug

Anbringen mit Dübel

Accessoires à percer



Viteria: acciaio inox.

Tornillería: acero inoxidable.

Fittings: stainless steel

Schrauben: Edelstahl

Visserie: acier inox.

Ottone cromato.

Latón cromado.

Chromed brass.

Messing verchromt

Laiton chromé



4QUATTRO

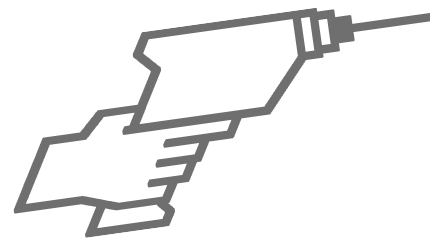

Appendino
Colgador // Hanger // Haken // Patère
cm 1,5 x 4,5 x h 1,5
Art. 7000KK



Portarotolo
Portarrotolos // Paper holder // Rollenhalter // Portero-rouleaux
cm 16 x 7 x h 1,5
Art. 7009KK



Portasalvietta
Toallero // Towel rack // Handtuchhalter // Porteserviette
cm 32 x 7 x h 1,5
Art. 7005KK



Portasapone vetro acidato
Jabonera cristal al ácido // Soap holder-acidified glass // Wandseifenschale-gesäuertes Kristallglas // Portesavon cristal acidé.
cm 13 x 12,5 x h 5,5
Art. 7001KK



Portasalvietta
Toallero // Towel rack // Handtuchhalter // Porteserviette
cm 48 x 7 x h 1,5
Art. 7006KK



Bicchieri vetro acidato
Portavasos cristal al ácido // Cup-acidified glass // Wandbecher-gesäuertes Kristallglas // Verre cristal acidé
cm 7 x 11,5 x h 12
Art. 7002KK



Portasalvietta
Toallero // Towel rack // Handtuchhalter // Porteserviette
cm 60 x 7 x h 1,5
Art. 7007KK



Dispenser vetro acidato
Dosificador cristal al ácido // Soap dispenser acidified glass // Wandseifenspender-gesäuertes Kristallglas // Doseur cristal acidé
cm 7,5 x 11,5 x h 20
Art. 7014KK



Portasalvietta a snodo
Toallero giratorio // Turning towel rack // Schwenkbarer Handtuchhalter // Porteserviette pivotant
cm 32 x 1,5 x h 9
Art. 7008KK



Scopino sospeso
Escobillero de pared // Wall toilet brush holder // Toilettenbürste Wandmodell // Porte-balai mural
cm 9,5 x 9,5 x h 55
Art. 7511KK

Scopino a terra
Escobillero de suelo // Toilet brush holder // Toilettenbürste // Porte-balai
cm 9,5 x 9,5 x h 55
Art. 7512KK



IL MONDO DELLA DOCCIA

EL MUNDO DE LA DUCHA

THE SHOWER'S WORLD

DIE WELT DER DUSCHE

LE MONDE DE LA DOUCHE



GRIGLIE

Design: Studio KOH-I-NOOR



KK

Ottone cromato.

*Latón cromado.
Chromed brass.
Messing verchromt
Laiton chromé*

Applicazione a tassello

*Se instala con taladro
Installation with plug
Anbringen mit Dübel
Accessoires à percer*

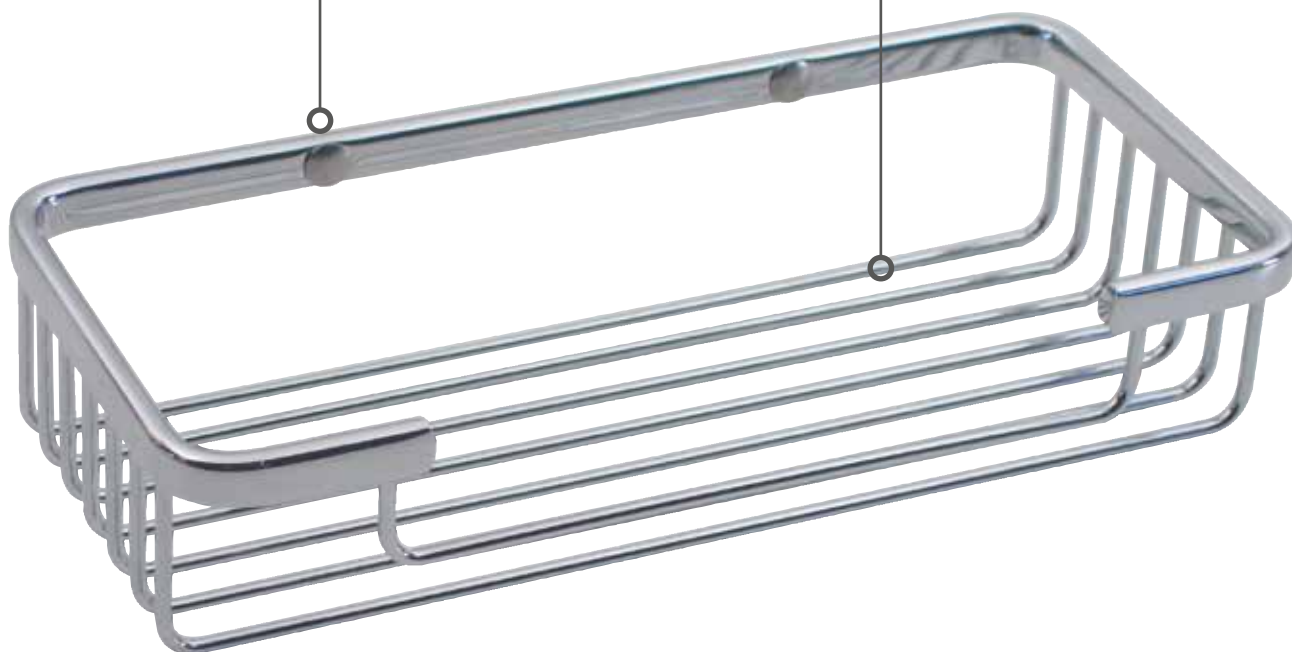

Applicazione con adesivo 3M

*Se instala con adhesivo 3M
Installation with adhesive 3M
Anbringen mit 3M Klebeband
Application avec adhésif 3M*



Supporti ABS cromato

*Soportes ABS cromado
Supports chromed ABS
Unterstützung verchromtes ABS
Supports ABS chromé*

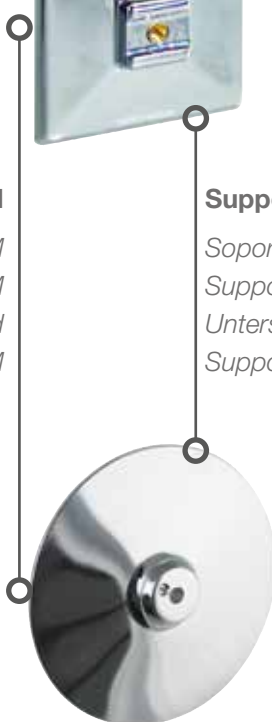



GRIGLIE

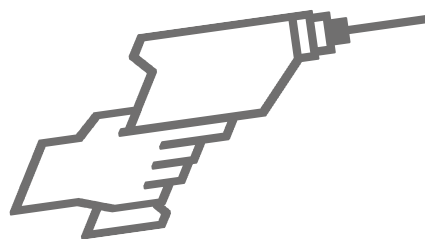

Cestino contenitore
 Contenedor // Container // Ablage // Panier
 cm 23,9 x 10,5 x h 8
 Art. 45809



Cestino contenitore
 Contenedor // Container // Ablage // Panier
 cm 19 x 19 x h 31
 Art. 45803



Cestino contenitore da appendere
 Contenedor // Container // Ablage // Panier
 cm 23,3 x 11 x h 76
 Art. 45810



Cestino contenitore
 Contenedor // Container // Ablage // Panier
 cm 35 x 12 x h 8
 Art. 45807



Cestino contenitore
 Contenedor // Container // Ablage // Panier
 cm 45 x 12 x h 8
 Art. 45808



Griglia doppia doccia rettangolare
 Contenedor doble // Hanging double shower Basket //
 Doppelte Ablage // Panier double
 cm 25 x 10 x h 75
 Art. 7522V
 Art. 7522N



Cestino contenitore
 Contenedor // Container // Ablage // Panier
 cm 19 x 19 x h 8
 Art. 45806



Cestino contenitore
 Contenedor // Container // Ablage // Panier
 cm 23,3 x 10,5 x h 7,5/5
 Art. 45802



Supporto adesivo per cestino
 Soportes adhesivo para contenedor // Adhesive
 supports for container // Klebehalterungen // Supports
 adhésif pour panier
 cm 19 x 19 x h 8/11,7
 Art. 5798KK



Supporto adesivo per cestino
 Soportes adhesivo para contenedor // Adhesive
 supports for container // Klebehalterungen // Supports
 adhésif pour panier
 ø cm 7,5 x h 1,5
 Art. 6198KK

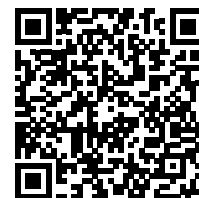

VIDEO INSTRUCTIONS



SEDILE 1

Design: Talocci + Pallocca

Sedile doccia ribaltabile
Asiento de ducha abatible
Folding shower seat
Duschklappsitz
Siège de douche rabattable

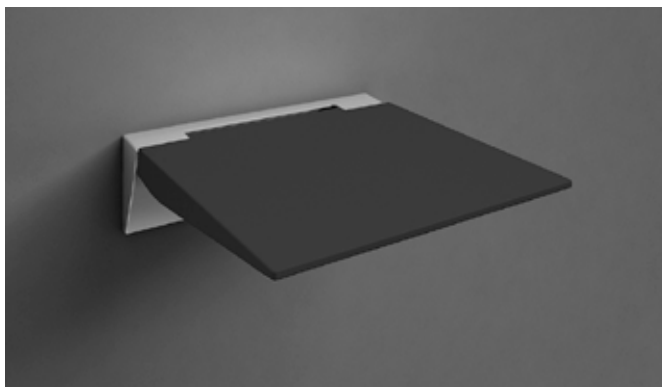

Struttura in alluminio lucido, seduta in ABS, viteria in acciaio inox
Estructura en aluminio brillo, asiento en ABS, tornilleria en inox
Polished aluminum structure, ABS seat, stainless steel screws
Struktur aus glänzendem Aluminium, Sitz aus ABS, Schrauben aus Edelstahl
Structure en aluminium brillant, siège en ABS, vis en acier inox

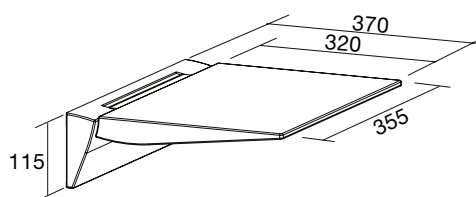

Art. 5468KV
Art. 5468KN



SEDILE 2

Sedile doccia ribaltabile
Asiento de ducha abatible
Folding shower seat
Duschkappsitz
Siège de douche rabattable

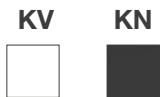

Materiali // Materiales // Materials // Material // Matériaux

Struttura in alluminio lucido, seduta in ABS, viteria in acciaio inox
Estructura en aluminio brillo, asiento en ABS, tornillería en inox
Polished aluminum structure, ABS seat, stainless steel screws
Struktur aus glänzendem Aluminium, Sitz aus ABS, Schrauben aus Edelstahl
Structure en aluminium brillant, siège en ABS, vis en acier inox

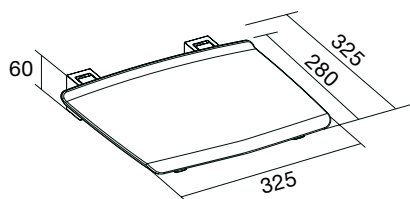

Art. 5469KV

Art. 5469KN



SGABELLO

Design: Talocci + Pallocca

Sgabello
Taburete
Stool
Hocker
Tabouret

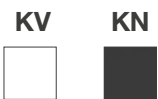

Materiali // Materiales // Materials // Material // Matériaux

Struttura in alluminio lucido, seduta in ABS, viteria in acciaio inox
Estructura en aluminio brillo, asiento en ABS, tornillería en inox
Polished aluminum structure, ABS seat, stainless steel screws
Struktur aus glänzendem Aluminium, Sitz aus ABS, Schrauben aus Edelstahl
Structure en aluminium brillant, siège en ABS, vis en acier inox

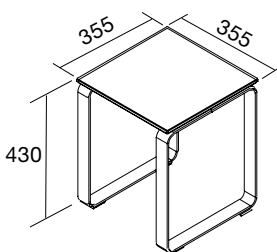

Art. 5470KV

Art. 5470KN





TENDE DOCCIA

Design: Studio KOH-I-NOOR

Tende per doccia
Cortinas de baño
Shower curtains
Duschvorhänge
Rideaux de douche

Materiali // Materiales // Materials // Material // Matériaux

Tessuto 100% poliestere impermeabilizzato. Anelli trasparenti.
Tejido 100% de poliéster. impermeabilizad. Anillas transparentes.
Fabric 100% polyester water proofed. Transparent rings.
Stoff 100% Polyester imprägniert. Transparente Ringe.
Tissu 100% polyester traité imperméable. Anneaux transparents.

Finiture // Acabados // Finishing // Ausführungen // Finitions

Linum

Art. 45222 (cm 180 x h200)

Art. 45223 (cm 240 x h200)

Linum



Canvass

Art. 45220 (cm 180 x h200)

Art. 45221 (cm 240 x h200)

Canvass



Midas Silver

Art. 45228 (cm 180 x h200)

Art. 45229 (cm 240 x h200)

Midas Silver





Linum



Canvass



Midas Silver

REVERSO PLUS

Tappeto reversibile per il bagno by Sorema
 Alfombras reversibles de baño by Sorema
 Reversible bath mat by Sorema
 Wendebadteppiche by Sorema
 Tapis de bain réversible by Sorema

Bianco

Acquamarina

Tortora

Grigio chiaro

Grigio scuro

Nero

L (cm) H (cm) Art.

Bianco <i>Blanco</i> <i>White</i> <i>Weiß</i> <i>Blanc</i>	50	70	35695
	60	90	35696
	70	120	35697
Acquamarina <i>Turquesa</i> <i>Turquoise</i> <i>Türkis</i> <i>Turquoise</i>	50	70	35713
	60	90	35714
	70	120	35715
Tortora <i>Tortola</i> <i>Dove grey</i> <i>Taubengrau</i> <i>Gris tourterelle</i>	50	70	35716
	60	90	35717
	70	120	35718

L (cm) H (cm) Art.

Grigio chiaro <i>Gris claro</i> <i>Light grey</i> <i>Hellgrau</i> <i>Gris clair</i>	50	70	35689
	60	90	35690
	70	120	35691
Grigio scuro <i>Gris oscuro</i> <i>Dark grey</i> <i>Dunkelgrau</i> <i>Gris foncé</i>	50	70	35719
	60	90	35720
	70	120	35721
Nero <i>Negro</i> <i>Black</i> <i>Schwarz</i> <i>Noir</i>	50	70	35710
	60	90	35711
	70	120	35712

Materiali // Materiales // Materials // Material // Matériaux

100% cotone pettinato e mercerizzato 1700 g/m²

100% algodón peinado y mercerizado 1700 g/m²

100% cotton combed and mercerized 1700 g/m²

100% Baumwolle gekämmt und merzerisiert 1700 g/m²

100% coton peigné et e mercerisé 1700 g/m²

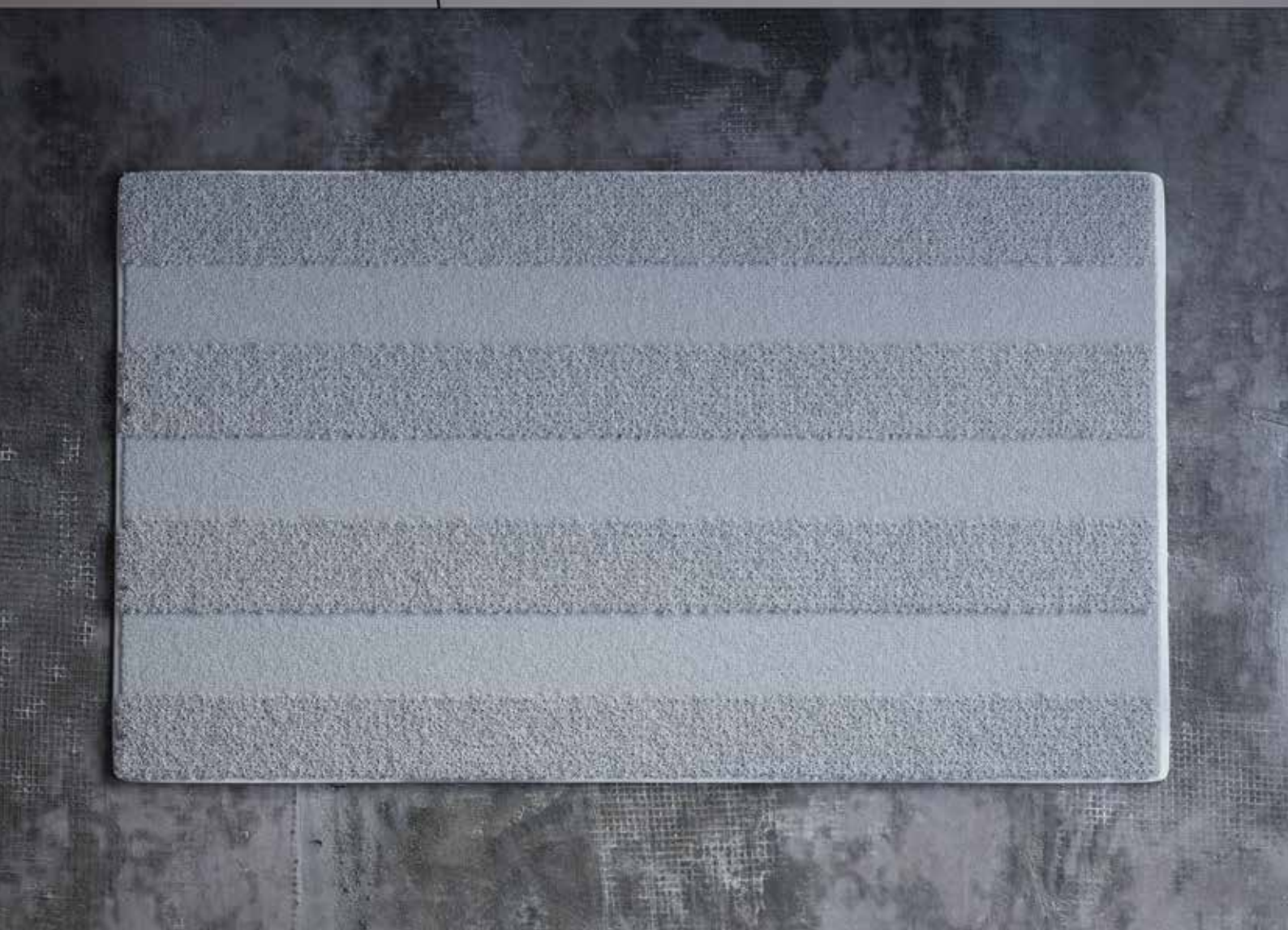

MANIGLIONI

Maniglioni di sicurezza. Alluminio cromato
 Manillón de seguridad. Aluminio cromado
 Safety grab rail. Chromed aluminium
 Poignée de sécurité (solution p.m.r.). Aluminium chromé
 Sicherheitswandgriffe. Verchromtes Aluminium

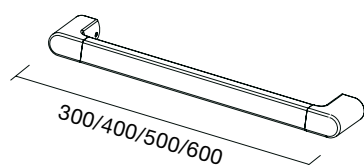
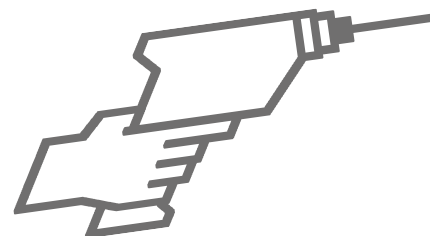

Maniglione

Asidero fijo // Holding handle // Wandhaltegriff // Barre d'appui (p.m.r.)

- Art. 45112 mm 300
- Art. 45113 mm 400
- Art. 45114 mm 500
- Art. 45115 mm 600

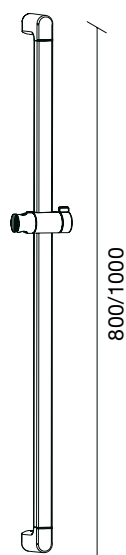

Sostegno per doccia con saliscendi

Soporte para brazo de ducha // Holding handle with shower holder // Haltegriff vertikal mit Brausehalter // Appui pour douche avec barre coulissante

- Art. 45120 mm 800
- Art. 45121 mm 1000

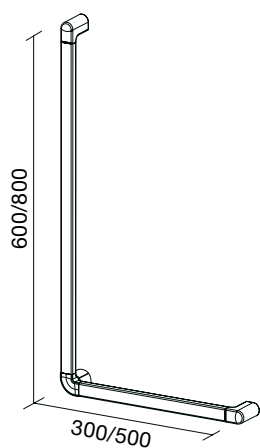

Maniglione 90° reversibile

Asidero fijo 90° reversible // Wall handle 90° reversible // Wandhaltegriff 90° reversibel // Appui pour douche à 90° avec barre coulissante

- Art. 45118 mm 300x600
- Art. 45119 mm 500x800

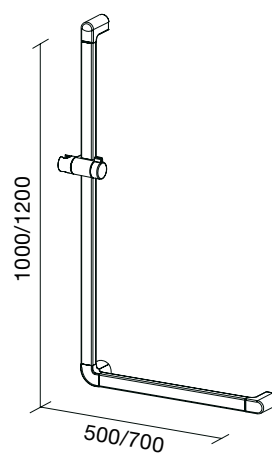

Sostegno per doccia a 90° con saliscendi

Soporte para brazo de ducha 90° // Holding handle 90° with shower holder // Haltegriff 90° mit Brausehalter // Appui pour douche à 90°, montage avec angle à droite /gauche au choix

- Art. 45122 mm 500x1000
- Art. 45123 mm 700x1200



Design: A.M. design



MANIGLIONI

Materiali // Materiales // Materials // Material // Matériaux

Maniglioni di sicurezza. Acciaio inox cromato
Manillón-asa de seguridad. Acero inox cromado
Safety grab rail. Chromed stainless steel
Sicherheitswandgriffe. Verchromter Edelstahl
Poignée de sécurité. Acier inox chromé

EN 12182 : 2012 93/42/CE

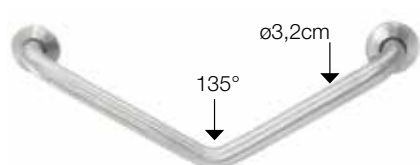
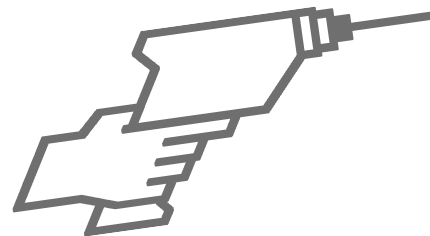

Maniglione
Manillón-asa baño // Grab rail // Wandgriff // Poigné
cm 49 x 7 x h 8
Art. 45111

Finiture // Acabados // Finishing // Ausführungen // Finitions

KK

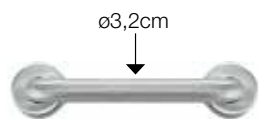

Maniglione
Manillón-asa baño // Grab rail // Wandgriff // Poigné
cm 30 x 7 x h 8
Art. 45109

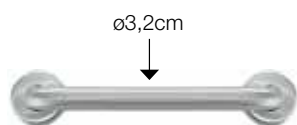

Maniglione
Manillón-asa baño // Grab rail // Wandgriff // Poignée
cm 45 x 7 x h 8
Art. 45110

ANTISCIVOLO

Design: Studio KOH-I-NOOR

Tappetini di sicurezza antiscivolo resistenti allo sporco, alla muffa e allo scolorimento. Lavabili in lavatrice.
 Alfombras de seguridad antideslizantes, resistentes a la suciedad, al moho y a la decoloración. Lavable a máquina.
 The anti-slip safety bath mats are resistant against dirt, mould and discolouration. Machine washable.
 Matten die das Ausrutschen verhindern, schmutzabweisend, resistent gegen Schimmel und Ausbleichen. Maschinenwaschbar.
 Les tapis de sécurité antidérapants sont résistants à la saleté, au moisi et à la décoloration. Lavable en machine.

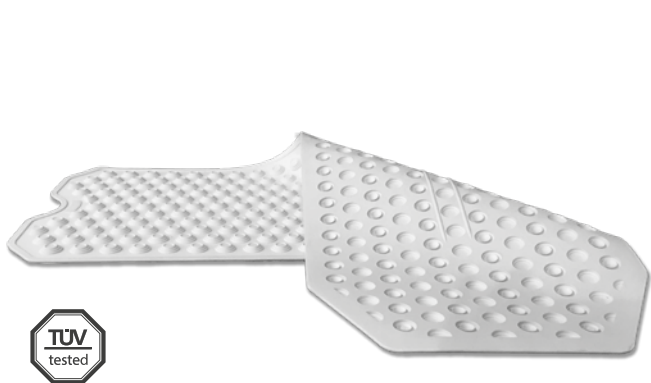

Materiali // Materiales // Materials // Material // Matériaux

Polietilene // Polietileno // Polyethylene // Polyäthylen // Polyethylene.

Materiali // Materiales // Materials // Material // Matériaux

Gomma // Goma // Rubber // Gummi // Caoutchouc.

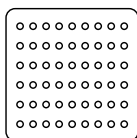

45023
 cm 60 x 60
 Art. 45023B

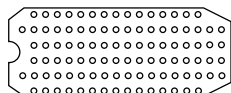

45022
 cm 40 x 104
 Art. 45022B

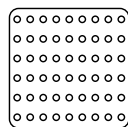

45007
 cm 53 x 53
 Art. 45007

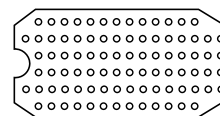

45008
 cm 36 x 73
 Art. 45008

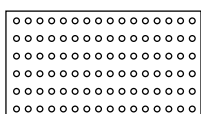

45012
 cm 60 x 80
 Art. 45012

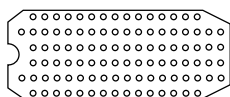

45011
 cm 40 x 104
 Art. 45011

BENESSERE

Design: Studio KOH-I-NOOR

Cura del corpo
Cuidado del cuerpo
Body care
Körperpflege
Soin du corps

Materiali // Materiales // Materials // Material // Matériaux

Fibra naturale Loofah. Fibra naturale Sisal. Spugne naturali mediterranee
Loofah. Sisal. Esponja natural
Natural fiber Loofah. Natural fiber Sisal. Natural mediterranean sponges
Loofah. Sisal. Naturschwämme
Loofah. Sisal. Éponges naturelles.



Fascia Sisal

*Banda de sisal para masaje // Massage glove, Sisal //
Band Sisal // Bande, Sisal*

cm 58/60 x 20

Art. S5



Guanto Massaggio Loofah

*Guante de masaje, Loofah // Massage glove, Loofah / Massagehandschuh Loofah
// Gant de massage, Loofah*

Art. G4



Guanto Massaggio Loofah

*Guante de masaje, Loofah // Massage glove, Loofah / Massagehandschuh Loofah
// Gant de massage, Loofah*

Art. ML-PL3



Disco Massaggio Loofah

*Disco de masaje, Loofah // Massage disc, Loofah / Massagescheibe Loofah //
Disque de massage, Loofah*

Art. OL1



Spugna naturale, bagno-doccia

Esponja natural, baño-ducha // Natural sponge, bath-shower // Naturschwamm, Bad-Dusche // Éponge naturelle, bain / douche

cm 8 - 19

Art. 5M (cm 8-9)

Art. 7M (cm 10-11)



Spugna naturale, bagno-doccia

Esponja natural, baño-ducha // Natural sponge, bath-shower // Naturschwamm, Bad-Dusche // Éponge naturelle, bain / douche

cm 8 - 19

Art. 9M (cm 12-13)

Art. 11M (cm 15-16)

Art. 13M (cm 18-19)



V

N

Spazzola da bagno

Cepillo de baño cerdas naturales // Bath brush // Badebürste // Brosse de baignoire

Art. SC127 V

Art. SC127 N

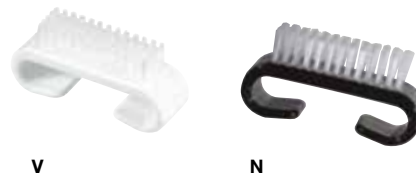

V

N

Spazzolino per unghie

Cepillo de uñas // Nail brush // Nagelbürste // Brosse à ongles

Art. SC130 V

Art. SC130 N

COMPLEMENTI D'ARREDO

COMPLEMENTOS DE DECORACIÓN

COMPLEMENTS

EINRICHTUNGSZUBEHÖR

COMPLÉMENTS
POUR LA SALLE DE BAIN





Sacca interna in cotone

*Bolsa interior de algodón
Cotton inner bag
Innensack aus Baumwolle
Sac intérieur en coton*

Struttura MDF, rivestimento interno in tessuto

*Estructura de MDF, forro de tela
MDF structure, fabric lining
Struktur aus MDF, Innenfutter aus Stoff
Structure en MDF, doublure en tissu*

Coperchio rimovibile

*Tapa extraíble
Removable lid
Abnehmbarer deckel
Couvercle amovible*

Maniglia

*Asas
Handle
Griffe
Poignée*

Rivestimento esterno in poliestere imitazione lino con trattamento idrorepellente

*Revestimiento de poliéster de imitación lino, con con tratamiento hidrófugo.
External in linen imitation polyester, with water-repellent coating.
Außen mit wasserabweisendem Polyester-Leinenimitat bezogen.
Revêtement en polyester imitation lin, avec traitement déperlant*



STRESA

Design: ErvasBasilicoGirardi

Porta biancheria con sacca interna, gettacarta.
Contenedor de ropa con bolsa interna, papelera.
Hamper with internal bag, waste basket
Wäschekorb mit Innensack, Abfallbehälter
Panier à linge avec sac à l'intérieur, poubelle

Materiali // Materiales // Materials // Material // Matériaux

Rivestimento esterno in poliestere imitazione lino, con trattamento idrorepellente. Interno in tessuto sintetico. Struttura in MDF
Revestimiento de poliéster de imitación lino, con con tratamiento hidrófugo. Interior de tejido sintético. Estructura en MDF (tablero de fibra de madera)
External in linen imitation polyester, with water-repellent coating. Synthetic fabric interior. Structure in MDF fibreboard.
Außen mit wasserabweisendem Polyester-Leinenimitat bezogen. Innenseite Syntyhetikstoff. Struktur MDF-Faserplatte.
Revêtement en polyester imitation lin, avec traitement déperlant. Intérieur en tissu synthétique. Structure en MDF



CR

Ecrú

*Crujo
Ecrú
Ecrú
Ecrú*



GR

Grigio

*Gris
Grey
Grau
Gris*



SB

Marrone

*Marron
Brown
Braun
Marrón*

Porta biancheria, con sacca interna

Contenedor de ropa, con bolsa interna // Hamper, with internal bag // Wäschekorb, mit Innensack // Panier à linge, avec sac à l'intérieur

ø cm 42 h62,5

Art. 3163CR

Art. 3163GR

Art. 3163SB

Porta biancheria con sacca interna, gettacarta.
Contenedor de ropa con bolsa interna, papelera.
Hamper with internal bag, waste basket
Wäschekorb mit Innensack, Abfallbehälter
Panier à linge avec sac à l'intérieur, poubelle



CR



GR



SB

Gettacarta con contenitore interno in plastica estraibile

Papelera con contenedor interno extraíble // Waste basket with inner plastic container // Abfallbehälter mit herausnehmbarem Innenbehälter aus Plastik // Poubelle avec récipient en plastique amovible

ø cm 23 x h 30

Art. 3103CR

Art. 3103GR

Art. 3103SB



BELLAGIO

Design: ErvasBasilicoGirardi

Porta biancheria con sacca interna, gettacarta.
Contenedor de ropa con bolsa interna, papelera.
Hamper with internal bag, waste basket
Wäschekorb mit Innensack, Abfallbehälter
Panier à linge avec sac à l'intérieur, poubelle

Materiali // Materiales // Materials // Material // Matériaux

Rivestimento esterno in poliestere imitazione lino, con trattamento idrorepellente. Interno in tessuto sintetico. Struttura in MDF
Revestimiento de poliéster de imitación lino, con con tratamiento hidrófugo. Interior de tejido sintético. Estructura en MDF (tablero de fibra de madera)
External in linen imitation polyester, with water-repellent coating. Synthetic fabric interior. Structure in MDF fibreboard.
Außen mit wasserabweisendem Polyester-Leinenimitat bezogen. Innenseite Syntyhetikstoff. Struktur MDF-Faserplatte.



CR

Ecu
Crudo
Ecu
Ecu
Ecu



GR

Grigio
Gris
Grey
Grau
Gris



SB

Marrone
Marron
Brown
Braun
Marrón

Porta biancheria, con sacca interna

Contenedor de ropa, con bolsa interna // Hamper, with internal bag // Wäschekorb, mit Innensack // Panier à linge, avec sac à l'intérieur

cm 50,5 x 32 x h62,5

Art. 3063CR

Art. 3063GR

Art. 3063SB



CR



GR



SB

Gettacarta con contenitore interno in plastica estraibile

Papelera con contenedor interno extraíble // Waste basket with inner plastic container // Abfallbehälter mit herausnehmbarem Innenbehälter aus Plastik // Poubelle avec récipient en plastique amovible

ø cm 23 x h 30

Art. 3103CR

Art. 3103GR

Art. 3103SB



ECOPELLE

Design: Studio KOH-I-NOOR e Monica Cerina

Cuciture esterne a vista

Costuras exteriores visibles
External visible seams
Außen sichtbare Nähte
Coutures extérieures visibles

Struttura MDF, rivestimento interno in tessuto

Estructura de MDF, forro de tela
MDF structure, fabric lining
Struktur aus MDF, Innenfutter aus Stoff
Structure en MDF, doublure en tissu



Maniglie

Asas
Handles
Griffe
Poignées

Rivestimento in ecopelle

Tapicería de piel sintética
Faux leather upholstery
Polsterung aus Kunstleder
Revêtement en faux cuir

Sacca interna in cotone

Bolsa interior de algodón
Cotton inner bag
Innensack aus Baumwolle
Sac intérieur en coton



ECOPELLE

Design: Studio KOH-I-NOOR e Monica Cerina

Porta biancheria con sacca interna, gettacarta.
Contenedor de ropa con bolsa interna, papelera.
Hamper with internal bag, waste basket
Wäschekorb mit Innensack, Abfallbehälter
Panier à linge avec sac à l'intérieur, poubelle

Materiali // Materiales // Materials // Material // Matériaux

Rivestimento esterno in eco pelle, interno in tessuto sintetico. Struttura in MDF.
Revestimiento de piel ecológica, interno en tejido sintético. Estructura en MDF.(tablero de fibra de madera).
External synthetic leather, lining synthetic cloth. Structure of MDF fibreboard.
Außen synthetisches Leder, innen Synthetikstoff. Struktur MDF Faserplatte.
Revêtement en cuir synthétique, intérieur en tissu synthétique. Structure en panneau de fibres MDF.



Porta biancheria, con sacca interna

Contenedor de ropa, con bolsa interna // Hamper, with internal bag // Wäschekorb, mit Innensack // Panier à linge, avec sac à l'intérieur

cm 48 x 30 x h 61

Art. 2463DB
Art. 2463CR
Art. 2463GR
Art. 2463TO
Art. 2463BK
Art. 2263BG
Art. 2263AR
Art. 2263VV
Art. 2563SV
Art. 2563SK

Porta biancheria, con sacca interna

Contenedor de ropa, con bolsa interna // Hamper, with internal bag // Wäschekorb, mit Innensack // Panier à linge, avec sac à l'intérieur

cm 43 x 26 x h 48

Art. 2462DB
Art. 2462CR
Art. 2462GR
Art. 2462TO
Art. 2462BK
Art. 2262BG
Art. 2262AR
Art. 2262VV
Art. 2562SV
Art. 2562SK

Gettacarta

Papelera // Waste basket // Abfallbehälter // Poubelle

cm 23 x 23 x h 30



2603DB

Testa di moro

Marrón oscuro
Dark brown
Dunkelbraun
Marron foncé



2603BK

Nero

Negro
Black
Schwarz
Noir



2603GR

Grigio

Gris
Grey
Grau
Gris



2603CR

Crema

Crema
Cream
Crème



2603TO

Tortora

Gris taupe
Dove grey
Taubengrau
Gris pigeon



2203VV

Bianco

Blanco
White
Weiß
Blanc



2203AR

Argento

Plata
Silver
Silber
Argent



2203BG

Oro

Oro
Gold
Gold
Or



2503SV

Bianco perlato

Blanco perla
Pearl white
Perlweiß
Blanc nacré



2503SK

Argento perlato

Plata perlada
Pearl silver
Perlsilber
Argent perlé

ECOPELLE VINTAGE

Design: Studio KOH-I-NOOR

Porta biancheria con sacca interna, gettacarta.
Contenedor de ropa con bolsa interna, papelera.
Hamper with internal bag, waste basket
Wäschekorb mit Innensack, Abfallbehälter
Panier à linge avec sac à l'intérieur, poubelle

Materiali // Materiales // Materials // Material // Matériaux

Rivestimento esterno in ecopelle lavorata a mano, interno in tessuto sintetico. Struttura in MDF.
Revestimiento de ecopiel trabajada a mano, interno en tejido sintético. Estructura en MDF. (tablero de fibra de madera)
External handmade eco-leather, lining synthetic cloth. Structure of MDF fibreboard.
Von Hand verarbeitetes Kunstleder, innen Synthetikstoff. Struktur MDF Faserplatte.
Revêtement en eco-cuir fait main, intérieur en tissu synthétique. Structure en panneau de fibres MDF.



SB

Marrone

Marron
Brown
Braun
Marrón



GR

Grigio

Gris
Grey
Grau
Gris



BK

Nero

Negro
Black
Schwarz
Noir

Porta biancheria, con sacca interna

Contenedor de ropa, con bolsa interna // Hamper, with internal bag // Wäschekorb, mit Innensack // Panier à linge, avec sac à l'intérieur

cm 48 x 30 x h 61

Art. 2467SB

Art. 2467GR

Art. 2467BK



BK



GR



SB

Gettacarta con contenitore interno in plastica estraibile

Papelera con contenedor interno extraíble // Waste basket with inner plastic container // Abfallbehälter mit herausnehmbarem Innenbehälter aus Plastik // Poubelle avec récipient en plastique amovible

cm 23 x 23 x h 30

Art. 2403SB

Art. 2403GR

Art. 2403BK



ECOPELLE VELA

Design: Studio Itamar Harari

Porta biancheria con sacca interna
Contenedor de ropa con bolsa interna
Hamper with internal bag
Wäschekorb mit Innensack
Panier à linge avec sac à l'intérieur

Materiali // Materiales // Materials // Material // Matériaux

Rivestimento esterno in eco pelle, interno in tessuto sintetico. Struttura in MDF.
Revestimiento de piel ecológica, interno en tejido sintético. Estructura en MDF. (tablero de fibra de madera).
External synthetic leather, lining synthetic cloth. Structure of MDF fibreboard.
Außen synthetisches Leder, innen Synthetikstoff. Struktur MDF Faserplatte.
Revêtement en cuir synthétique, intérieur en tissu synthétique. Structure en panneau de fibres MDF.



GR

Grigio

Gris
Grey
Grau
Gris



TO

Tortora

Gris taupe
Dove grey
Taubengrau
Gris pigeon



DB

Testa di moro

Marrón oscuro
Dark brown
Dunkelbraun
Marron foncé



CR

Crema

Crema
Cream
Crème
Crème

Porta biancheria, con sacca interna

Contenedor de ropa, con bolsa interna // Hamper, with internal bag // Wäschekorb, mit Innensack // Panier à linge, avec sac à l'intérieur

cm 48,5 x 32 x h 61

Art. 2464GR

Art. 2464TO

Art. 2464DB

Art. 2464CR



Serie di elementi di arredo
 Serie de elementos contenedores
 Collection of furniture
 Möbelkollektion
 Collection de compléments



Materiali // Materiales // Materials // Material // Matériaux

Struttura: acciaio verniciato a polvere epossidica con finitura opaco. Mensola WT009: vetro extra chiaro laccato 6mm.
 Estructura: acero lacado con polvo epoxi, acabado mate. Repisa WT009: cristal extra claro lacado en de 6mm
 Structure: steel, painted with epoxy powder, matt finish. Shelf WT009: extra clear glass varnished 6mm.
 Struktur: mit Epoxypulverlack matt lackierter Stahl. Ablage WT009: aus lackiertem extralight Glas 6 mm
 Structure: acier verni à poudre époxy, avec finition mat. Étagère WT009: en verre extra léger laqué 6mm.

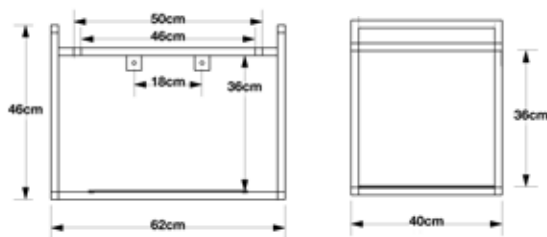
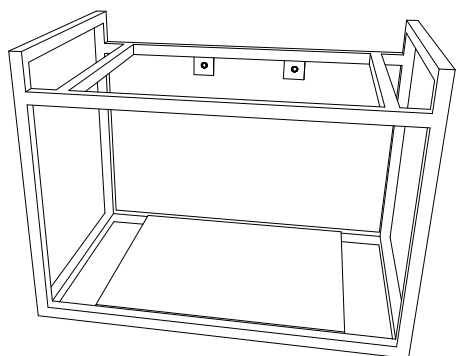

Struttura per lavabo con mensola e porta salviette

Estructura para lavabo con repisa y toallero // Structure for washbasin with shelf and towel rack // Struktur für Waschbecken, mit Ablage und Handtuchstange // Structure pour lavabo avec étagère et porte-serviette

cm 62 x 40 x h 46

Art. WT009N

Art. WT009V

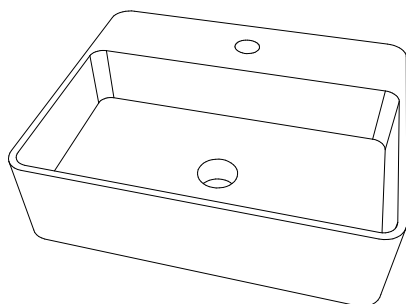

Lavabo Olympia in ceramica da appoggio monoforo, finitura opaca

Lavabo de ceramica sobremesa olympia con un agujero, acabado mate // Sit on ceramic washbasin Olympia, one hole, matt finish // Einlochwaschbecken aus Keramik Olympia, Ausführung matt // Lavabo olympia à poser, simple, en céramique finition mat

cm 50 x 41 x h 14

Art. TRA4250111V

Art. TRA4250123N

Art. TRA4150101V *Lucido / Brillante / Glossy / Glänzend / Brillant*

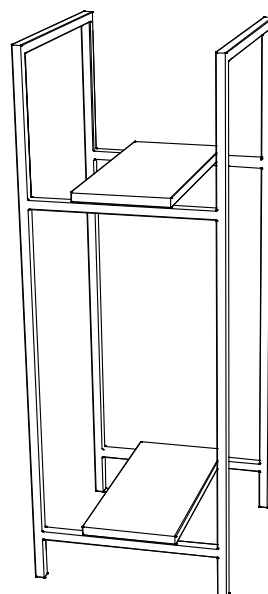

Piantana con mensola

Toallero de pie con repisa // Equipped stand with tray // Standregal // Étagère

cm 33 x 36 x h 90

Art. WT008N

Art. WT008V



WT008N

WT009N



WT008V

WT009V

GETTACARTA

Papelera
Waste basket
Abfallbehälter
Poubelle

Stresa / Bellagio

Design: ErvasBasilicoGirardi



3103CR



3103GR



3103SB

Ecrú

- 1
- 2
- 3
- 4

Grigio

- Grís*
Grey
Grau
Gris

Marrone

- Marron*
Brown
Braun
Marrón

ø cm 23 x h 30

Rivestimento esterno in poliestere imitazione lino, con trattamento idrorepellente. Interno in tessuto sintetico. Struttura in MDF

Revestimiento de poliéster de imitación lino, con con tratamiento hidrófugo. Interior de tejido sintético. Estructura en MDF (tablero de fibra de madera)

External in linen imitation polyester, with water-repellent coating. Synthetic fabric interior. Structure in MDF fibreboard.

Außen mit wasserabweisendem Polyester-Leinenimitat bezogen. Innenseite Synthetischstoff. Struktur MDF-Faserplatte.

Revêtement en polyester imitation lin, avec traitement déperlant. Intérieur en tissu synthétique. Structure en MDF

Vintage

Design: Studio KOH-I-NOOR



2403BK



2403GR



2403SB

Nero

- Negro*
Black
Schwarz
Noir

Grigio

- Grís*
Grey
Grau
Gris

Marrone

- Marron*
Brown
Braun
Marrón

ø cm 23 x h 30

Rivestimento esterno in ecopelle lavorata a mano, interno in tessuto sintetico. Struttura in MDF.

Revestimiento de ecopiel trabajada a mano, interno en tejido sintético. Estructura en MDF.(tablero de fibra de madera)

External handmade eco-leather, lining synthetic cloth. Structure of MDF fibreboard.

Von Hand verarbeitetes Kunstleder, innen Synthetischstoff. Struktur MDF Faserplatte.

Revêtement en éco-cuir fait main, intérieur en tissu synthétique. Structure en panneau de fibres MDF.

Ecopelle

Design: Studio KOH-I-NOOR e Monica Cerina



2603DB

Testa di moro

Marrón oscuro
Dark brown
Dunkelbraun
Marron foncé



2203AR

Argento

Plata
Silver
Silber
Argent



2603GR

Grigio

Gris
Grey
Grau
Gris

cm 23 x 23 x h 30

Rivestimento esterno in eco pelle, interno in tessuto sintetico. Struttura in MDF.

Revestimiento de piel ecológica, interno en tejido sintético. Estructura en MDF. (tablero de fibra de madera).

External synthetic leather, lining synthetic cloth. Structure of MDF fibreboard.

Außen synthetisches Leder, innen Synthetikstoff. Struktur MDF Faserplatte.

Revêtement en cuir synthétique, intérieur en tissu synthétique. Structure en panneau de fibres MDF.



2603BK

Nero

Negro
Black
Schwarz
Noir



2203VV

Bianco

Blanco
White
Weiß
Blanc



2503SK

Argento perlato

Plata perlada
Pearl silver
Perlsilber
Argent perlé



2603CR

Crema

Crema
Cream
Creme
Crème



2203BG

Oro

Oro
Gold
Gold
Or



2503SV

Bianco perlato

Blanco perla
Pearl white
Perlweiß
Blanc nacré



2603TO

Tortora

Gris taupe
Dove grey
Taubengrau
Gris pigeon

SCOPINI

Design: Studio KOH-I-NOOR

Escobillero de suelo
Toilet brush holder
Toilettenbürste
Porte-balai

Pepe

ø cm 12 x h 38

ABS colorato, ABS cromato galvanicamente, tappo antiscivolo, contenitore interno in polipropilene.

ABS coloreado, ABS cromado galvánicamente, tapa antideslizante, contenedor interno de polipropileno.

Coloured ABS, galvanized chromed ABS, transparent polycarbonate, anti-slip base, inside container in polypropylene.

farbiges ABS, galvanisch verchromtes ABS, rutschfester Boden, Innenbehälter aus Polypropylen.

ABS coloré, ABS chromé par galvanisation, fond anti-glisserment, récipient à l'intérieur en polypropylène.



5366KK

5266VV

Scopino a terra

Escobillero de suelo // Toilet brush holder // Toilettenbürste // Porte-balai

Kono

ø cm 9 x h 37

ABS colorato, ABS cromato galvanicamente, policarbonato trasparente, tappo antiscivolo a tenuta stagna.

ABS coloreado, ABS cromado galvánicamente, policarbonato transparente, tapa antideslizante y estanca.

Coloured ABS, galvanized chromed ABS, transparent polycarbonate, anti-slip, watertight base.

Farbiges ABS, galvanisch verchromtes ABS, transparentes Polykarbonat, wasserdichter rutschfester Boden.

ABS coloré, ABS chromé par galvanisation, polycarbonate transparent, fond antidérapant étanche.



5356KK

5256VV

Scopino a terra

Escobillero de suelo // Toilet brush holder // Toilettenbürste // Porte-balai

Piega - Lavi - Materia - LeM2.0 - LeM2.T - Tilda 4Quattro

ø cm 9 x h 38

Ottone pieno cromato o nero opaco. Viteria: acciaio inox.

Latón macizo cromado o negro mate. Tornillería: acero inoxidable.

Chromed or black mat full brass. Fittings: stainless steel

Massives Messing, verchromt oder matt schwarz. Schrauben: Edelstahl

Laiton massif chromé ou noir mat. Visserie: acier inox.



7512KK
Scopino a terra
 Escobillero de suelo //
 Toilet brush holder //
 Toilettenbürste // Porte-balai



7512V
Scopino a terra
 Escobillero de suelo //
 Toilet brush holder //
 Toilettenbürste // Porte-balai



7512N
Scopino a terra
 Escobillero de suelo //
 Toilet brush holder //
 Toilettenbürste // Porte-balai



7511KK
Scopino sospeso
 Escobillero de pared //
 Wall toilet brush holder //
 Toilettenbürste Wandmodell //
 // Porte-balai mural



7511V
Scopino sospeso
 Escobillero de pared //
 Wall toilet brush holder //
 Toilettenbürste Wandmodell //
 // Porte-balai mural



7511N
Scopino sospeso
 Escobillero de pared //
 Wall toilet brush holder //
 Toilettenbürste Wandmodell //
 // Porte-balai mural

Tito - 10 - Tubina - TubinaT

ø cm 9 x h 38

Ottone pieno cromato o nero opaco. Viteria: acciaio inox.

Latón macizo cromado o negro mate. Tornillería: acero inoxidable.

Chromed or black mat full brass. Fittings: stainless steel

Massives Messing, verchromt oder matt schwarz. Schrauben: Edelstahl

Laiton massif chromé ou noir mat. Visserie: acier inox.



6112KK
Scopino a terra
 Escobillero de suelo //
 Toilet brush holder //
 Toilettenbürste // Porte-balai



6112V
Scopino a terra
 Escobillero de suelo //
 Toilet brush holder //
 Toilettenbürste // Porte-balai



6112N
Scopino a terra
 Escobillero de suelo //
 Toilet brush holder //
 Toilettenbürste // Porte-balai

Supporto adesivo per scopino

Soportes adhesivo para escobillero // Adhesive supports for toilet brush // Toilettenbürsten-Klebehalter // Supports adhésif pour porte balai

Art. 7498



7411KK
Scopino sospeso
 Escobillero de pared //
 Wall toilet brush holder //
 Toilettenbürste Wandmodell //
 // Porte-balai mural



7411V
Scopino sospeso
 Escobillero de pared //
 Wall toilet brush holder //
 Toilettenbürste Wandmodell //
 // Porte-balai mural



7411N
Scopino sospeso
 Escobillero de pared //
 Wall toilet brush holder //
 Toilettenbürste Wandmodell //
 // Porte-balai mural

SKATTO

Sobremesa

Table top accessories

Kleines Zubehör

Accessoires à poser



Design: Studio KOH-I-NOOR

ABS cromato, ABS colorato.
ABS cromado, ABS coloreado.
Chromed ABS, coloured ABS.
Verchromtes ABS, farbiges ABS.
ABS chromé, ABS coloré.



KK



V



SKATTO Bicchiere

Portavasos // Cup // Becher
// Verre

ø cm 9 x h 10,5

Art. 5638KK

Art. 5638V



SKATTO Portasapone

Jabonera // Soap holder //
Seifenschale // Porte-savon

ø cm 11,3 x h 4,8

Art. 5630KK

Art. 5630V



SKATTO Portaspazzolini

Portacepillos // Toothbrush
holder // Zahnbürstenhalter
// Porte brosse à dents

ø cm 11,3 x h 13

Art. 5631KK

Art. 5631V



SKATTO Dispenser

Dosificador // Soap
dispenser // Seifenspender
// Doseur

ø cm 9 x h 16,8

Art. 5657KK

Art. 5657V

CLASSIC

Sobremesa
Table top accessories
Kleines Zubehör
Accessoires à poser



Design: Studio KOH-I-NOOR

ABS cromato galvanicamente.
ABS cromado galvánicamente.
Galvanized chromed ABS.
Galvanisch verchromtes ABS.
ABS chromé par galvanisation.



KK



CLASSIC Dispenser
Dosificador // Soap
dispenser // Seifenspender
// Doseur
ø cm 7,5 x h 15
Art. 5357KK



CLASSIC Bicchiere
Portavasos // Cup // Becher
// Verre
ø cm 7,5 x h 10
Art. 5338KK



CLASSIC Portasapone
Jabonera // Soap holder //
Seifenschale // Porte-savon
ø cm 11,5 x h 3,5
Art. 5330KK



CLASSIC Portaspazzolini
Portacepillos // Toothbrush
holder // Zahnbürstenhalter
// Porte broses à dents
ø cm 11,3 x h 12
Art. 5331KK



CLASSIC c
cm 25 x 13,5 x h 7
Art. 5359KK



CLASSIC Vaschetta
Portaobjetos // Tray //
Schale // Plateau
cm 25 x 11 h 3
Art. 5337KK

HOTELLERIE

Tutti i prodotti della collezione Hotellerie possono richiedere tempi di consegna maggiori.
Indicativamente 3 settimane dall'ordine.

Todos los productos de la colección Hotellerie pueden requerir plazos de entrega más largos.
Aproximadamente 3 semanas de pedido.

All products in the Hotellerie collection may require longer delivery times.
Approximately 3 weeks after order.

Alle Produkte der Hotellerie-Kollektion können längere Lieferzeiten erfordern.
Ungefähr 3 Wochen nach Bestellung.

Tous les produits de la collection Hotellerie peuvent nécessiter des délais de livraison plus longs.
Environ 3 semaines après la commande.





Specchi ingranditori in ottone (cromato / verniciato nero / rame / bronzo)

Especjos de aumento de latón (cromado / pintado de negro / cobre / bronce)

Brass magnifying mirrors (chrome-plated / painted black / copper / bronze)

Vergrößerungsspiegel aus Messing (verchromt / schwarz lackiert / Kupfer / Bronze)

Miroirs grossissants en laiton (chromé / peint en noir / cuivre / bronze)



Cromato
Cromado
Chrome plated
Verchromt
Chromé

Specchio ingranditore a 1 braccio Bifacciale

Espejo de aumento de 1 brazo Bifacial // 1-arm magnifying mirror Bifacial // 1-Arm-Lupenspiegel Bifacial // Miroir grossissant à 1 bras Bifacial

ø cm 20

Art. 8930G (x3)



Cromato
Cromado
Chrome plated
Verchromt
Chromé

Specchio ingranditore a 2 braccia Bifacciale

Espejo de aumento de 2 brazos Bifacial // Bifacial 2 arm magnifying mirror // Bifacial 2-Arm-Lupenspiegel // Miroir grossissant à 2 bras Bifacial

ø cm 20

Art. 8931G (x3)



Cromato
Cromado
Chrome plated
Verchromt
Chromé

Specchio ingranditore LED a 1 braccio Bifacciale

Espejo de una cara con iluminación LED // Single-sided mirror with LED lighting // Einseitiger Spiegel mit LED-Beleuchtung // Miroir simple face avec éclairage

ø cm 21,5

Art. 8934G (x3)



Verniciato nero
Pintado de negro
Painted black
Schwarz lackiert
Peint en noir

Specchio ingranditore a 1 braccio Bifacciale

Espejo de aumento de 1 brazo Bifacial // 1-arm magnifying mirror Bifacial // 1-Arm-Lupenspiegel Bifacial // Miroir grossissant à 1 bras Bifacial

ø cm 20

Art. 8936G (x3)



Verniciato nero
Pintado de negro
Painted black
Schwarz lackiert
Peint en noir

Specchio ingranditore LED a 1 braccio Bifacciale

Espejo de una cara con iluminación LED // Single-sided mirror with LED lighting // Einseitiger Spiegel mit LED-Beleuchtung // Miroir simple face avec éclairage

ø cm 21,5

Art. 8935G (x3)



Cromato
Cromado
Chrome plated
Verchromt
Chromé

Specchio ingranditore LED a 2 braccia Bifacciale

Espejo de una cara con iluminación LED // Single-sided mirror with LED lighting // Einseitiger Spiegel mit LED-Beleuchtung // Miroir simple face avec éclairage

ø cm 21,5

Art. 8933G (x3)



Verniciato bronzo
Pintado de bronce
Painted bronze
Bronze lackiert
Peint en bronze

Specchio ingranditore a 1 braccio Bifacciale

Espejo de aumento de 1 brazo Bifacial // 1-arm magnifying mirror Bifacial // 1-Arm-Lupenspiegel Bifacial // Miroir grossissant à 1 bras Bifacial

ø cm 20

Art. 8999G (x3)



Verniciato rame
Pintado de cobre
Painted copper
Kupfer lackiert
Peint en cuivre

Specchio ingranditore a 1 braccio Bifacciale

Espejo de aumento de 1 brazo Bifacial // 1-arm magnifying mirror Bifacial // 1-Arm-Lupenspiegel Bifacial // Miroir grossissant à 1 bras Bifacial

ø cm 20

Art. 9000G (x3)



Specchio ingranditore 1 braccio rettangolare

Espejo de aumento de 1 brazo // 1-arm magnifying mirror // 1-Arm-Lupenspiegel // Miroir grossissant à 1 bras

cm 20

Art. 9001G (x3)



Specchio ingranditore 1 braccio tondo

Espejo de aumento de 1 brazo // 1-arm magnifying mirror // 1-Arm-Lupenspiegel // Miroir grossissant à 1 bras

cm 20

Art. 9002G (x3)

Gettacarta inox aisi 304 con contenitore interno e chiusura con frizione lenta

Papelera acero inoxidable aisi 304 con contenedor interno y cierre de embrague lento

Waste paper bin stainless steel aisi 304 with internal container and slow-clutch closure

Papierkorb aus Edelstahl AISI 304 mit Innenbehälter und Slow-Clutch-Verschluss

Poubelle à papier en acier inoxydable aisi 304 avec conteneur interne et fermeture à embrayage lent



Cromo

Cromo // Chrome // Chrom // Chrome

Ø 20,3 x h 28,4 cm 5 litri

Art. 8950P



Nero

Negro // Black // Schwarz // Noir

Ø 20,3 x h 28,4 cm 5 litri

Art. 8951P



Cromo

Cromo // Chrome // Chrom // Chrome

cm 20 x 20 x h 29 6 litri

Art. 8952P



Grigio satinato

Gris satinado // Satin grey // Satingrau // Gris satiné

Ø 20,3 x h 28,4 cm 5 litri

Art. 9003P



Rame

Cobre // Copper // Kupfer // Cuivre

Ø 20,3 x h 28,4 cm 5 litri

Art. 9004P

Scopino inox aisi 304

Escobillero de acero inoxidable aisi 304

Stainless steel aisi 304 toilet brush

Toilettenbürste aus Edelstahl AISI 304

Brosse de toilette en acier inoxydable aisi 304



Ø 9 x h 37 cm

Art. 8920G



cm 8 x 8 x h40

Art. 8925GG



cm 8 x 8 x h40

Art. 8926GG

Accessori a muro
Accesorios de pared
Wall accessories
Zubehör für Wandmontage
Accessoires à fixer



Porta salviette mensola in ottone cromato
Toallero estante // Towel shelf // Handtuchablage // Étagère porte-serviettes
 cm 50 x 27 x 13.5
 Art. 8901G



Porta salviette mensola in ottone cromato
Toallero estante // Towel shelf // Handtuchablage // Étagère porte-serviettes
 cm 48.5 x 27 x 15
 Art. 8902G



Maniglione con portasapone in ottone cromato
Asidero de latón cromado con jabonera // Chrome-plated brass handle with soap dish // Verchromter Messinggriff mit Seifenschale // Poignée en laiton chromé avec porte-savon
 cm 12 x 45 x 12 Ø 2,5
 Art. 8910G



Cestino rettangolare in ottone con interno in ABS
Papelera rectangular de latón con interior de ABS // Rectangular brass wastebasket with ABS interior // Rechteckiger Papierkorb aus Messing mit ABS-Innenausstattung // Poubelle rectangulaire en laiton avec intérieur en ABS
 cm 30 x 12,4 x 5.3
 Art. 8914G



Cestino angolare in ottone con interno in ABS
Papelera esquinera de latón con interior de ABS // Corner brass waste bin with ABS interior // Eckiger Mülleimer aus Messing mit ABS-Innenausstattung // Poubelle d'angle en laiton avec intérieur en ABS
 cm 22 x 22 x 5.2
 Art. 8915G



Filo stendi biancheria in ottone cromato
Estensione fino a 3m
Extensión de tendedero de latón cromado de hasta 3m // Chromed brass clothesline extension up to 3m // Wäscheleinenverlängerung aus verchromtem Messing bis zu 3m // Extension de corde à linge en laiton chromé jusqu'à 3m
 Art. 8940G



Porta Kleenex inox aisi 304 lucido
Porta Kleenex de acero inoxidable aisi 304 pulido // Polished stainless steel aisi 304 Kleenex holder // Kleenex-Halter aus poliertem Edelstahl AISI 304 // Porte Kleenex en acier inoxydable aisi 304 poli
 cm 27 x 10 x 10.5
 Art. 8960GG



Porta Kleenex inox aisi 304 nero
Porta Kleenex de acero inoxidable aisi 304 negro // Black aisi 304 stainless steel Kleenex holder // Kleenex-Halter aus schwarzem Edelstahl AISI 304 // Porte Kleenex en acier inoxydable aisi 304 noir
 cm 27 x 10 x 10.5
 Art. 8961GG

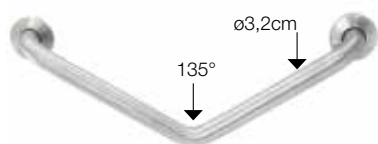

Maniglione
Manillón-asa baño // Grab rail // Wandgriff // Poignée
 cm 49 x 7 x h 8
 Art. 45111

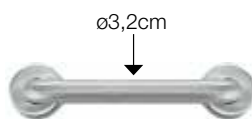

Maniglione
Manillón-asa baño // Grab rail // Wandgriff // Poigné
 cm 30 x 7 x h 8
 Art. 45109

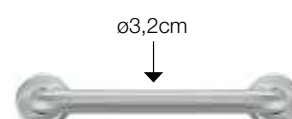

Maniglione
Manillón-asa baño // Grab rail // Wandgriff // Poignée
 cm 45 x 7 x h 8
 Art. 45110



Igiene e protezione
Higiene y protección
Hygiene and protection
Hygiene und Schutz
Hygiène et protection



Porta sacchetti igienici in ABS cromato lucido
Portarrollos ABS cromado pulido // Polished chrome-plated ABS toilet bag holder // Polierter, verchromter ABS-Toilettenbeutelhalter // Porte-papier de toilette en ABS chromé poli
cm 13,5 x 9,5 x 2,5

Art. 8962G



Porta sacchetti igienici in inox aisi 304 lucido
Portarrollos acero inoxidable aisi 304 pulido // Toilet bag holder stainless steel aisi 304 polished // Kulturbbeutelhalter aus Edelstahl AISI 304 poliert // Porte-papier de toilette en acier inoxydable aisi 304 poli

cm 10 x 2,5 x 14

Art. 8963GG



Porta sacchetti igienici in inox aisi 304 nero
Portarrollos acero inoxidable aisi 304 negro // Toilet bag holder stainless steel aisi 304 black // Kulturbbeutelhalter aus Edelstahl AISI 304 schwarz // Porte-papier de toilette en acier inoxydable aisi 304 noir

cm 10 x 2,5 x 14

Art. 8964GG



Porta sacchetti igienici in inox aisi 301 lucido
Portarrollos acero inoxidable aisi 301 pulido // Toilet bag holder stainless steel aisi 301 polished // Kulturbbeutelhalter aus Edelstahl AISI 301 poliert // Support de trousse de toilette en acier inoxydable aisi 301 poli

cm 13,5 x 3,5 x 28

Art. 8965GG



Porta sacchetti igienici in inox aisi 301 nero
Portarrollos acero inoxidable aisi 301 negro // Toilet bag holder stainless steel aisi 301 black // Kulturbbeutelhalter aus Edelstahl AISI 301 schwarz // Support de trousse de toilette en acier inoxydable aisi 301 noir

cm 13,5 x 3,5 x 28

Art. 8966GG



Generatore di ozono 10 gr/h
Generador de ozono 10 gr/h // Ozone generator 10 gr/h // Ozongenerator 10 gr/h // Générateur d'ozone 10 gr/h

cm 26,5 x 17 x 19,5

Art. KIN-10G

Accessori per zone comuni inox aisi 304

Accesorios para zonas comunes acero inoxidable aisi 304

Accessories for common areas stainless steel aisi 304

Zubehör für Gemeinschaftsräume Edelstahl AISI 304

Accessoires pour les espaces communs en acier inoxydable aisi 304



Distributore asciugamani piegati con serratura (400 fogli)

Dispensador de toallas plegadas con cierre (400 hojas) // Folded towel dispenser with lock (400 sheets) // Spender für gefaltete Handtücher mit Schloss (400 Blatt) // Distributeur de serviettes pliées avec serrure (400 feuilles)

cm 25 x 12 h 42

Art. 8967GG / 8968GG



Distributore carta igienica interfogliata con serratura

Dispensador de papel higiénico intercalado con cerradura // Interleaved toilet paper dispenser with lock // Spender für gefaltetes Toilettenpapier mit Schloss // Distributeur de papier toilette intercalaire avec serrure

cm 13,5 x 11 h 30

Art. 8977GG / 8978GG



Asciugamani aria cyclon

Secamanos de aire Cyclon // Cyclon air hand dryer // Cyclon Luft-Händetrockner // Sèche-mains à air comprimé

2450W

Art. 8990N



Dispenser parete in ottone cromato

Dispensador mural de latón cromado
Chrome-plated brass wall dispenser
Wandspender aus verchromtem Messing
Distributeur mural en laiton chromé

cm 12,3 x 20,4 x 5,4 (250ml)

Art. 8970G



Asciugacapelli
Secador de pelo
Hairdryer
Fön
Sèche-cheveux



Executive Bianco

2 velocità, 2 temperature, Termostato di sicurezza

*2 velocidad, 2 temperaturas, termostato de seguridad
2 speed, 2 temperatures, safety thermostat
2 Geschwindigkeiten, 2 Temperaturen,
Sicherheitsthermostat
2 vitesses, 2 températures, thermostat de sécurité*

1200W

Art. 8981G



Comfort Pro Bianco/Cromo

3 velocità, 3 temperature, Termostato di sicurezza

*3 velocidad, 3 temperaturas, termostato de seguridad
3 speed, 3 temperatures, safety thermostat
3 Geschwindigkeiten, 3 Temperaturen,
Sicherheitsthermostat
3 vitesses, 3 températures, thermostat de sécurité*

1800W

Art. 8982G



Comfort Plus Nero/Cromo

2 velocità, 2 temperature, Termostato di sicurezza

*2 velocidad, 2 temperaturas, termostato de seguridad
2 speed, 2 temperatures, safety thermostat
2 Geschwindigkeiten, 2 Temperaturen,
Sicherheitsthermostat
2 vitesses, 2 températures, thermostat de sécurité*

1300W

Art. 8983G

RICAMBI

Piezas de recambio
Spare parts
Ersatzteile
Pièces de rechange

Manico + ciuffo scopino

Mango y cepillo escobillero
Handle and brush
Griff und Bürste
Manche et brosse



Art.

RC6111KK Tubina
RC5911KK Lavi
RC6011KK Materia
RC6111KK 10
RC811KK LeM 2.0/Lem 2.T
RC267KK Tilda
RC267KK Akka
RC356... Kono
RC362... Pepe
RC380KK Gigi
RC267... Toldo
RC7011 4Quattro
RC7111S Tratto

Interno in plastica scopino

Contenedor interno escobillero
Plastic container
Plastikinnenbehälter
Récipient en plastique

Art.

AC5031F Tubina
AC5267IG Akka
AC5366FL Pepe
AC5380I Gigi
AC5267IG Toldo
AC5380IG Lavi
AC5380IG Materia
AC6111F 10
AC 5380I LeM 2.0/LeM 2.T
AC5267IG Tilda
AC5031F 4Quattro
AC7111N Tratto

NEW: AC7511F
(Bianco // Blanco // White // Weiß // Blanc)

NEW: AC7511FN
(Nero // Negro // Black // Schwarz // Noir)

Ciuffo scopino

Cepillo escobillero
Brush
Bürste
Brosse



Art.

RCAMBI050 Tubina
RCAMBI080 Lavi
RCAMBI070 Materia
RCAMBI050 10
RCAMBI080 LeM 2.0/Lem 2.T
RCAMBI050 Tilda
RCAMBI050 4Quattro
RCAMBI050 Akka
RCAMBI056 Kono
RCAMBI062 Pepe
RCAMBI080 Gigi
RCAMBI050 Toldo
RCAMBI090 Tratto

NEW: RCAMBI050
(Bianco // Blanco // White // Weiß // Blanc)

NEW: RCAMBI050N
(Nero // Negro // Black // Schwarz // Noir)

Contenitore interno dispenser

Contenedor interno dosificador
Inside container for dispenser
Innenbehälter für Seifenspender
Récipient à l'intérieur pour doseur

Art.

RC5657 Skatto

Pompetta cromo per tutti i dispenser

Bomba cromo dosificador
Chrome pump for all dispenser
Pumpe für Seifenspender chrom
Pompe pour doseur chrome

Art.

AVPOMP

Portasapone

*Jabonera
Soap holder
Seifenschale
Porte-savon*

Art.

K630 Materia

R5417T 10

K630 Tilda

V7001 4Quattro

K630 Tratto

K7417 Tito

Sacca interna per portabiancheria

*Bolsa interna para contenedor de roba
Internal bag for hampers
Innensack für Wäschekorb
Sac intérieur pour panier à linge*

Art.

S2462 | 2462/2562/2962/2262

S2463 | 2463/2563/2963/2263

Bicchieri

*Vaso
Cup
Becher
Verre*

Art.

K638 Materia

R5418T 10

K638 Tilda

V7002 4Quattro

K638 Tratto

K7418 TITO

Lente

*Lente
Lens
Vergrößerungsglas
Verre*

Art.

R199-3 Quadrolo x3

R199S-3 Quadrolo Led x3

R219 Discolo x2

R219-3 Discolo x3

R219SG Discolo Led x2

R219SG-3 Discolo Led x3

Dispenser

*Dosificador
Soap dispenser
Seifenspender
Doseur*

Art.

K657 Materia

R5416T 10

K657 Tilda

V7015 4Quattro

K657 Tratto

CONDIZIONI GENERALI DI VENDITA

Condiciones generales de venta (exportación)
General sale conditions (export)
Allgemeine Verkaufsbedingungen (export)
Conditions générales de vente (exportation)

PREMESSA

Le presenti condizioni generali si applicano insieme alle eventuali condizioni speciali contemplate nei contratti di vendita.

PREZZI

I prezzi del presente listino si intendono per merce resa in porto franco iva esclusa e sono espressi in euro e possono essere modificati in qualsiasi momento senza alcun obbligo di preavviso.

ORDINI

Gli ordini sono sottoposti all'accettazione delle sedi e si intendono tacitamente e integralmente subordinati alle condizioni di vendita stabilite.

SPEDIZIONI E RECLAMI

La merce viaggia a rischio e pericolo del committente. Il destinatario è tenuto a controllare la merce ricevuta e a contestare per iscritto eventuali danni direttamente al vettore e al venditore entro 8 giorni dalla data di ricevimento dei prodotti. Eventuali reclami relativi a difetti non individuabili mediante un diligente controllo al momento del ricevimento della merce dovranno essere notificati al venditore per iscritto comunque non oltre 12 mesi dalla consegna. Non si accettano resi di merce se non preventivamente autorizzati per iscritto dal venditore.

RESA

La merce è resa in porto franco. Per ordini di valore netto inferiore a € 300,00 verrà addebitato in fattura l'importo di €15,00 quale contributo per spese amministrative e di trasporto.

PAGAMENTO

In caso di mancato o ritardato pagamento rispetto alla data pattuita il venditore è autorizzato a sospendere l'esecuzione delle forniture in corso e ad annullare i contratti in essere. In caso di ritardato pagamento il compratore sarà tenuto a corrispondere al venditore sulla somma dovuta gli interessi di mora nella misura del tasso ufficiale di sconto aumentato di 4 punti.

PRIVACY

Ai sensi dell'articolo 13 del decreto legge n° 196/2003 Koh-i-noor srl comunica che i dati personali comunicati dall'acquirente saranno conservati nel proprio archivio e saranno utilizzati esclusivamente per adempimenti connessi all'attività economica.

FORO COMPETENTE

Per qualsiasi controversia tra le parti sarà esclusivamente competente il foro di Varese.

INTRODUCCIÓN

Las presentes condiciones generales se aplican junto a las eventuales condiciones especiales contempladas en los contratos de venta.

PRECIOS

Salvo acuerdos específicos, los precios de la presente tarifa se entienden por mercancía "entregada en fábrica" (Ex Works) sin incluir IVA.

PEDIDOS

Los pedidos son sometidos a la aceptación de la empresa y se entienden tácitamente e integralmente subordinados a las condiciones de venta establecidas.

ENVÍOS Y RECLAMACIONES

La mercancía viaja por cuenta y riesgo del cliente. El destinatario debe controlar la mercancía recibida y comunicar directamente por escrito eventuales daños al transportista. Eventuales reclamaciones relativas a defectos no detectables a través de un control al momento de la recepción de la mercancía, deberán ser notificadas por escrito al vendedor antes de los 12 meses de la fecha de entrega. No se aceptan devoluciones de mercancía si no son autorizadas previamente por escrito por el vendedor.

ENTREGAS

Salvo acuerdos específicos, la mercancía se entrega en condiciones "en fábrica" (Ex Works) sin incluir IVA.

PAGO

En caso de devolución o retraso en el pago con respecto de la fecha pactada, el vendedor está autorizado a suspender la ejecución de los suministros en curso y a anular los contratos en vigor. En caso de retraso en el pago el comprador deberá responder al vendedor con los intereses de demora en la medida del tipo bancario incrementada en 4 puntos, sobre la suma adeudada.

PRIVACIDAD DE LOS DATOS

De acuerdo con el artículo 13 del decreto ley n° 196/2003 Koh-i-noor srl comunica que los datos personales aportados por el comprador serán conservados en archivo propio y serán utilizados exclusivamente con relación a la actividad económica.

FORO COMPETENCIAL

Por cualquier litigio entre las partes será exclusivamente competente el tribunal de Varese.

PREAMBLE

These general conditions are applicable together with any special conditions contained in the sales contracts.

PRICES

Unless otherwise agreed, the prices in this price-list are for goods delivered ex works VAT excluded and are expressed in Euros and may be changed at any time without prior notice.

ORDERS

Orders are submitted for acceptance to the head office and are tacitly and wholly subject to the established sales conditions.

SHIPMENTS AND CLAIMS

The goods travel at the consignee's risk. The consignee is required to inspect the goods received and report any damage directly to the carrier. The seller must be advised of any claims regarding defects, not detectable by diligent inspection on the receipt of the goods, not later than 12 months from the date of delivery. No goods can be returned without the prior written authorization of the seller.

DELIVERY

Unless otherwise agreed, goods shall be delivered ex works VAT excluded.

PAYMENT

In default of payment, at the agreed payment date, the seller shall be authorized to suspend any order in progress and cancel outstanding contracts.

In case of delayed payment, the buyer shall be obliged to pay interest on the outstanding amount at the official rate plus 4 %.

PRIVACY

According to Article 13 of the Legislative Decree 196/2003, Koh-i-noor S.p.A. hereby declares that any personal data provided by the buyer shall be stored in its archives and shall be used exclusively for business-related procedures.

PLACE OF JURISDICTION

Any controversy between the parties, shall be of the exclusive competence of the Court of Varese.

ALLGEMEINE GELTUNG

Die allgemeinen Geschäftsbedingungen kommen zusammen mit den in den Verkaufsverträgen vorgesehenen Sonderbedingungen zur Anwendung.

PREISE

Falls nicht anders vereinbart verstehen sich die Preise für Lieferung ab Werk, Mehrwertsteuer ausgeschlossen.

AUFTRÄGE

Die Aufträge unterliegen der Zustimmung des Verkäufers und sind stillschweigend und vollständig durch die vereinbarten Geschäftsbedingungen geregelt.

VERSAND UND BESCHWERDEN

Der Transport erfolgt auf Gefahr des Käufers.

Der Käufer ist zur Kontrolle der erhaltenen Ware verpflichtet. Mängelrügen müssen innerhalb von 8 Tagen schriftlich beim Verkäufer eingehen. Mängel, die auch durch eine sorgfältige Kontrolle beim Erhalt der Ware nicht festgestellt werden können, müssen dem Verkäufer innerhalb von 12 Monaten nach der Zustellung schriftlich mitgeteilt werden. Warenrücksendungen werden nur nach vorheriger schriftlicher Genehmigung des Verkäufers angenommen.

LIEFERUNG

Wenn nicht anders vereinbart, erfolgt die Lieferung ab Werk.

ZAHLUNG

Bei Zahlungsverzug ist der Verkäufer berechtigt, von noch ausstehenden Leistungen zurückzutreten und bestehende Verträge zu annullieren.

DATENSCHUTZ

Gemäß Artikel 13 des Gesetzeserlasses Nr. 196/2003 teilt Koh-i-noor Srl mit, dass die vom Käufer mitgeteilten persönlichen Daten im Firmenarchiv aufbewahrt und ausschließlich für die Durchführung wirtschaftlicher Aktivitäten verwendet werden.

GERICHTSSTAND

Für alle Kontroversen zwischen den Parteien ist ausschließlich Varese der zuständige Gerichtsstand.

INTRODUCTION

Les présentes conditions générales s'appliquent également aux éventuelles conditions spéciales mentionnées dans les contrats de vente.

PRIX

Sauf autre accord, les prix de la présente liste sont considérés pour la marchandise livrée franco usine TVA non comprise, ils s'entendent en Euros et peuvent être modifiés à tout moment sans préavis obligatoire.

COMMANDES

Les commandes sont soumises à l'approbation du siège et elles sont subordonnées, sauf dérogation expresse, aux conditions de vente préétablies.

EXPÉDITIONS ET RÉCLAMATIONS

La marchandise voyage aux risques et périls du client. Le destinataire est tenu de faire toutes constatations nécessaires et de confirmer ses réserves par écrit directement au transporteur. Les éventuelles réclamations, relatives à des défauts non identifiables par un contrôle minutieux au moment de la réception de la marchandise devront être communiquées au vendeur par écrit avant les 12 mois qui suivent la livraison. Aucune restitution de marchandise, ne sera acceptée si elle n'a pas été préalablement autorisée par le vendeur.

LIVRAISON

Sauf dérogation expresse, la marchandise est livrée franco usine TVA non comprise.

PAIEMENT

En cas de défaut ou de retard de paiement par rapport à la date établie, le vendeur sera autorisé à suspendre l'exécution des fournitures en cours et à annuler les contrats en vigueur. En cas de retard du paiement, l'acquéreur sera tenu de reconnaître au vendeur les intérêts moratoires calculés au taux d'escompte officiel majoré du quatre pour cent.

CONFIDENTIALITÉ

Aux termes de l'article 13 du décret-loi n° 196/2003 Koh-i-Noor srl communique que les données personnelles communiquées par l'acquéreur seront conservées dans ses archives et qu'elles seront utilisées exclusivement pour des mesures liées aux activités économiques.

TRIBUNAUX COMPÉTENTS

Toute contestation susceptible de surgir entre les parties sera de la seule compétence du tribunal de Varèse.





KOH-I-NOOR Carlo Scavini & C. Srl

Via Meucci, 10
21049 Tradate (VA) Italia
Tel. +39 0331842272 // Fax +39 0331842921
www.koh-i-noor.it // info@koh-i-noor.it



Design KOH-I-NOOR Distribution s.l.

Poligono Industrial Can Salvatella c/. Torrent Tortuguer, 38-40
08210 Barberá del Vallés (Barcelona) España
tel 93.747.95.84
www.bagnodkd.es // dkd@bagnodkd.es



FOLLOW US



Download .pdf

